



Cowles Foundation

for Research in Economics
at Yale University

Cowles Foundation Discussion Paper No. 1760R

THE ROLE OF COMMITMENT IN BILATERAL TRADE

Dino Gerardi, Johannes Horner and Lucas Maestri

May 2010
Revised October 2013

An author index to the working papers in the
Cowles Foundation Discussion Paper Series is located at:
<http://cowles.econ.yale.edu/>

This paper can be downloaded without charge from the
Social Science Research Network Electronic Paper Collection:
<http://ssrn.com/abstract=2334345>

The Role of Commitment in Bilateral Trade*

Dino Gerardi[†], Johannes Hörner[‡], Lucas Maestri[§]

October 1, 2013

Abstract

This paper solves for the set of equilibrium payoffs in bargaining with interdependent values when the informed party makes all offers, as discounting vanishes. The seller of a good is informed of its quality, which affects both his cost and the buyer's valuation, but the buyer is not. To characterize this payoff set, we derive an upper bound, using mechanism design with limited commitment. We then prove that this upper bound is tight, by showing that all its extreme points are equilibrium payoffs. Our results shed light on the role of different forms of commitment on the bargaining process. In particular, we show that it is the buyer's inability to commit to a contract before observing the terms of trade that precludes efficiency.

Keywords: bargaining, mechanism design, market for lemons.

JEL codes: C70, C78, D82

1 Introduction

With few exceptions, non-cooperative theories of bargaining concern themselves with the extreme cases of full commitment or no commitment whatsoever. Mechanism design neglects

*We thank an Associate Editor and two referees, as well as Joel Watson for useful comments, Sofia Moroni for careful proofreading, and various seminar audiences.

[†]Collegio Carlo Alberto, Torino, Italy. dino.gerardi@carloalberto.org.

[‡]Yale University, 30 Hillhouse Ave., New Haven, CT 06520, USA. johannes.horner@yale.edu.

[§]Toulouse School of Economics, Manufacture des Tabacs, Aile Jean-Jacques Laffont MF 52421, allée de Brienne 31000, Toulouse, France. maestri.lucas@gmail.com.

the problem of credibility, whereas infinite-horizon bargaining following Rubinstein (1982) revels in the asymptotic study of the equilibrium outcome as frictions, interpreted as commitment power, disappear.

Plainly, the context of most actual exchanges lies somewhere between these theoretical benchmarks. Caveat emptor rarely applies, nor does unrestrained consumer protection.¹ Lack of information, for instance, is often raised by courts as an argument for calling a contract unconscionable. To be sure, the onus is on the buyer to exercise due diligence when evaluating whether a good is worth the purchase price. But a contract that would ask for the buyer to commit to it before knowing whether and what price trade will take place, for instance, would be difficult to judicially enforce. As Gresik (1991a) has pointed out, buyers can rarely be coerced into accepting offers that make them worse off.² Yet this is one of the main prescription of mechanism design.

Our goal is to understand whether and how commitment matters. To do so, we consider a standard model of trade, with one buyer and one seller. The setting is that of the lemon problem, as introduced by Akerlof (1970), the simplest framework for trade under interdependent values, an essential feature for the discussion. The seller knows both the value and cost of the unit, while the buyer does not.³ There is common knowledge of gains from trade.

The full commitment problem has been thoroughly investigated by Samuelson (1984) and Myerson (1985), and their findings provide the starting point for our analysis. As already pointed out by Myerson (1981), optimal mechanisms with interdependent values can exhibit surprising properties. In particular, in our problem, the optimal mechanism need not satisfy posterior individual rationality. That is, the buyer may lose from participating in the mechanism given the information that this mechanism reveals: if the buyer were to reconsider his willingness-

¹The inadequacy of theoretical analysis for contract law has been denounced by Posner (2002), for instance. However, there are important exceptions to this neglect, from Schelling (1956) to Williamson (1983).

²Entry fees are an important exception, as they are sunk. Entry fees are rarely allowed in bargaining games—the focus of our paper. This is not to say that entry fees are irrelevant in practice. On the contrary, our analysis delineates the potential role of such fees.

³By a simple change of variable, all our results apply to the case in which it is the buyer who is informed and who makes offers, and the seller is uninformed.

to-trade in light of the offer that he is supposed to accept, given that this offer leads him to re-evaluate his expected value for the unit, he may very well prefer to pass.

Giving such veto power to the buyer is the second step in our analysis. Note that this is not equivalent to *ex post* individual rationality, a stronger requirement that posits that the buyer gains given the actual state of nature. The difference matters here, since values are interdependent (see Gresik 1991b, Forges 1994 and Matthews and Postlewaite 1989). This property, which we refer to as *veto-incentive compatibility*, following Forges (1999), imposes restrictions on the mapping from reported types to the distribution over offers that the mechanism specifies. Veto-incentive compatibility, then, is a requirement on the graph of this map: conditional on any given offer, the posterior belief of the buyer should be such that he is willing to accept this offer. As one immediately suspects, restricting attention to deterministic offers would entail a loss of generality. This does not mean that the buyer accepts a random price; rather, the price he accepts has been chosen randomly.

Veto-incentive compatibility is not only a restriction on mechanisms that is realistic, given current legal and commercial practices, it is also *implied* by standard bargaining protocols. We prove, in particular, that it is automatically satisfied whenever at most one of the players –buyer or seller– makes an offer *per* round, whether or not this order is pre-determined, stochastic, history-dependent, etc., and whether the horizon is finite or not.

We characterize veto-incentive compatible mechanisms. First, we show that, if there are finitely many types (an assumption our model does not impose), it is enough to consider as many offers as types. Moreover, the k -th highest offer can only come the k -th highest or higher seller's types.⁴ More importantly, we show that whether a given allocation can be implemented in a veto-incentive compatible way or not is a property of (the map from reports to) the probability of trade and expected price alone. The problem reduces then to a standard optimal control problem, to which variational techniques can be applied. The interesting feature is the property

⁴This result is reminiscent of Bester and Strausz (2001), although our environment does not fit their model. First, we have a continuum of types. Second, we are not in their single-agent environment.

imposed by veto-incentive compatibility: the necessary and sufficient condition is that the buyer's *ex ante* payoff, conditional on trading with all types above a given threshold be nonnegative, for all possible values of this threshold.

Our last step is the case that is usually associated with complete lack of commitment. This is the infinite-horizon bargaining game. We focus on the case in which the seller makes all the offers. Clearly, the resulting outcome must satisfy veto-incentive compatibility, since the buyer can reject any given offer. Clearly also, the temporal monopoly of the seller provides him with a lower bound on his payoff, no matter how patient players are. More precisely, his lowest type can still secure a price equal to the buyer's lowest possible cost. We prove that, along with veto-incentive compatibility, this is the only further constraint imposed by bargaining: every payoff vector that can be achieved by a veto-incentive compatible allocation and that gives the seller this security payoff is an equilibrium payoff vector if the two players are patient enough. This might sound like a folk theorem, but this only holds in terms of payoffs: there are allocations that are veto-incentive compatible, and give the seller his security payoff, and yet cannot be implemented in the bargaining game.

Our results have striking implications. First, under the sufficient conditions we provide (roughly, high gains from trade or low information rents) bargaining achieves constrained efficiency. In those circumstances, commitment has no benefits whatsoever. Second, if bargaining fails to attain efficiency, then trading institutions are only useful for efficiency if they manage to weaken the veto-incentive compatibility constraint, as is the case, for instance, when the uninformed party is asked to commit to a screening contract. Nothing in between helps.

From a practical point of view, these results imply that, within the context of the lemons problem, the theoretical predictions we (or others) obtain for these three cases (commitment, veto-incentive compatibility and no commitment) carry over to institutions with commitment that is in between.

However, our result is only about *ex ante* payoffs: Sequential rationality imposes further

constraints in bargaining, since for instance, both the seller's and the buyer's payoffs must be individually rational, not only from the *ex ante* point of view, but from any history onward. As we show, there are allocations that are veto-incentive compatible and give the seller his security payoff, and yet cannot be implemented in the bargaining game. Furthermore, this “folk” theorem does not extend to interim payoffs, and might not even include the equilibrium payoff of the game in which the buyer makes all the offers (Deneckere and Liang, 2006). Somewhat surprisingly, these other constraints do not affect the set of *ex ante* payoffs.

With respect to the bargaining literature, together with Deneckere and Liang's, this paper clarifies the role of the proposer's identity. For instance, the most efficient equilibrium outcome when the seller makes all the offers is strictly more efficient than the equilibrium outcome when the buyer makes the offers. Sometimes, even the most inefficient equilibrium does better.

Among related papers, Ausubel and Deneckere (1989) analyze the link between mechanism design and bargaining in the special case of private values (with one-sided incomplete information). They show that, when the uninformed party makes all the offers, a folk theorem holds. That is, every incentive compatible, individually rational, direct bargaining mechanism is implementable by sequential equilibria, if the frequency of offers is high enough. On the other hand, if the informed party makes the offer, a unique equilibrium outcome gets singled out as the frequency of offers increases. Our paper establishes that, as one would suspect, lack of commitment imposes more constraints with interdependent values than with private values. Interestingly though, the set of equilibrium payoffs that can be achieved remains fairly easy to characterize, as the feasible set of some programming problem. The paper by Deneckere and Liang that was already mentioned provides a careful analysis of the bargaining game in which the (uninformed) buyer makes all the offers, and they prove that the equilibrium outcome is then unique. We comment further on the relationship with Deneckere and Liang as we proceed.

Section 2 defines the set-up. The main results are in Section 3, with a sketch of proof provided in Section 4. (The full proof is available in an online appendix.) Section 5 offers extensions.

2 The Set-Up

2.1 The Trading Problem

Consider a trading problem in which player 1, the *seller*, owns an indivisible object that player 2, the *buyer*, wants to purchase. The two players are risk-neutral, with quasi-linear utility. The players' valuations are determined by the realization of a random variable that is uniformly distributed over the unit interval, $t \sim \mathcal{U}[0, 1]$. That is, given t , the seller's cost and the buyer's value for the object are given by $c(t)$ and $v(t)$ respectively. The functions $c : [0, 1] \rightarrow \mathbb{R}_+$ and $v : [0, 1] \rightarrow \mathbb{R}_+$ are assumed to be non-decreasing and piecewise continuously C^1 . We also assume that c is piecewise C^1 on $(0, 1)$. Because v need not be constant, this environment displays interdependent values, of which private values is a special case. The assumption that t is uniformly distributed is made with no loss of generality, given the restrictions imposed on v and c .⁵

Information is asymmetric. The seller is informed of the realization of the random variable, and so knows both his cost and the buyer's value. We refer to this realization as the seller's *type* $t \in T := [0, 1]$. The buyer, on the other hand, does not observe this realization. However, he knows the distribution of the random variable, and the functions v and c are common knowledge.

In particular, it is common knowledge that there are gains from trade. That is, we assume that $v(t) > c(t)$.⁶ This neither precludes nor implies that the first-best allocation is attainable if individual rationality is imposed. Such a first-best mechanism is individually rational if and only if the buyer's expected value exceeds the seller's highest cost (see Lemma 1 of Deneckere and Liang, 2006). While our results can be adapted to this case, the trading problem becomes

⁵In an online appendix (Appendix C), we discuss what happens when c and v are not both monotonic. Sufficiency from Proposition 1 survives, and simple necessary and sufficient conditions are provided under which the *ex ante* efficient payoff in the full commitment is an equilibrium payoff under bargaining as frictions vanish.

⁶The main results –Theorem 1, Proposition 1, Proposition 2, Theorems 2 and 3– also hold under the weaker condition $v \geq c$, as long as there are finitely many types. Our proofs involve a series of approximation of the cost and value functions by step functions, and we have not verified that the limit results extend to the case of a weak inequality.

then uninteresting, and we will rule it out.

Our purpose is to characterize the equilibrium payoffs in the bargaining game in which the seller makes all offers. To do so, we must understand what allocations can be achieved under limited commitment. First, we shall consider the case in which the buyer cannot be forced to trade if the actual offer that is being made leads to a negative expected payoff. Following Forges (1999), we refer to this assumption as *veto-incentive compatibility*. Given the mechanism, and for any outstanding offer, the buyer updates his expected value for the object. Veto-incentive compatibility requires this conditional expectation to exceed the offer, whenever the mechanism specifies trade in this event. This captures the notion that, in most trading environments, buyers can always reject an offer for which they anticipate a loss. In the words of Gresik (1991a), “in most markets each trader has the ability to refuse to trade when the “best” negotiated terms give him negative utility.” For instance, a seller who puts up an object for sale in an auction house commits to the eventual outcome, given the auction mechanism, but potential buyers can drop out at any stage of the auction process. Note that, with interdependent values, this does not ensure that the buyer will not experience regret, that is, that his realized value will exceed the price that he paid. In many markets, there is not much a buyer can do to renege on a purchase for which his experienced utility falls short of the price that he paid. In this sense, the trade need not be *ex post* individually rational. (The two notions coincide in the case of private values.) At the time of purchase, however, the potential buyer cannot be forced to accept an outstanding offer, if he anticipates a loss, simply because he chose to participate in the trading process.

The set of payoffs that can be achieved under this mechanism (as well as under the standard “full-commitment” mechanism) will then be compared to the set of payoffs in the infinite-horizon bargaining game with discounting, in which the seller makes all the offers.

2.2 Mechanisms

Direct mechanisms, that require the seller to report his type, provide a way for setting the terms of trade. To be more formal, a *direct mechanism* is a probability transition μ from T to $\{0, 1\} \times \mathbb{R}_+$.^{7,8} A direct mechanism, then, specifies whether trade occurs (the outcome “1” is interpreted as trade, while the outcome “0” means no trade), and at what price, according to some joint distribution, and given the announcement of the seller. We let $x(t)$ denote the probability of trade, given the announcement t . That is,

$$x(t) := \mu(t)[1, \mathbb{R}_+]. \quad (1)$$

Without loss of generality, we assume that no payment is made if no trade occurs, that is, we assume that $\mu(t)[0, \{0\}] = 1 - x(t)$. If $x(t) > 0$, we let $p(t)$ denote the expected price, given the announcement t , *i.e.*

$$p(t) := \int_{\mathbb{R}_+} p \mu(t)[1, dp] / x(t), \quad (2)$$

and set $p(t) := 0$ otherwise. Given $x : T \rightarrow [0, 1]$ and $p : T \rightarrow \mathbb{R}_+$, the *allocation* (x, p) is *implementable* if there exists a mechanism μ (which *implements* (x, p)) such that x and p coincide everywhere with the functions that are defined by (1) and (2).

It follows from the revelation principle that attention can be restricted to direct mechanisms in which the seller announces his type truthfully. Furthermore, under commitment, attention can be restricted to mechanisms in which prices are deterministic, *i.e.* $p(t)$ is the only price assigned positive probability by $\mu(t)[1, \cdot]$, for all t .

Given some direct mechanism μ , the payoff to the seller of type t that reports s is given by

$$\pi^S(s | t) := x(s)[p(s) - c(t)].$$

⁷That is, for each $t \in T$, $\mu(t)$ is a probability distribution on $\{0, 1\} \times \mathbb{R}_+$, and the probability $\mu(\cdot)[A]$ assigned to any Borel set $A \subset \{0, 1\} \times \mathbb{R}_+$ is a measurable function of $t \in T$. That attention can be restricted to distributions over the probability of trade and payment is a consequence of the revelation principle.

⁸It is not hard to see that the restriction to offers in \mathbb{R}_+ rather than \mathbb{R} is without loss of generality for those allocations, and hence payoffs, that we seek to characterize.

The mechanism μ is *incentive compatible* if, for all $s, t \in T$, $\pi^S(t) := \pi^S(t | t) \geq \pi^S(s | t)$. We shall also be interested in the *ex ante* payoff of the seller before his type is determined, that is, given some incentive compatible mechanism μ ,

$$\pi^S = \mathbb{E}_t[\pi^S(t)] = \int_T \pi^S(t) dt = \int_T x(t)[p(t) - c(t)] dt. \quad (3)$$

Fix some incentive compatible mechanism μ . Suppose that the buyer is offered to trade at some price p in the support of $\mu(t)[1, \cdot]$ for some $t \in T$. What is his expected payoff, conditional on this outcome $(1, p)$? Given the mechanism μ , fix a version of the conditional distribution $\nu : (\{0, 1\} \times \mathbb{R}_+) \times \mathcal{B} \rightarrow [0, 1]$, where \mathcal{B} is the Borel field on T . Given $\mathcal{T} \in \mathcal{B}$, we write $\nu(\mathcal{T} | p)$ for $\nu((1, p), \mathcal{T})$, the conditional probability assigned to the seller's type being in the set \mathcal{T} , given the event $(1, p)$ (with an abuse of notation, we also write $\nu(t | p)$ for $\nu(\{t\} | p)$). The buyer's expected payoff, given p , is then

$$\pi^B(p) := \int_T v(t) d\nu(t | p) - p.$$

The *ex ante* payoff of the buyer is given by

$$\pi^B := \int_T x(t)[v(t) - p(t)] dt. \quad (4)$$

An incentive compatible mechanism μ is *individually rational* if $\pi^S(t) \geq 0$ for all $t \in T$, and $\pi^B \geq 0$. Further, it is *veto-incentive compatible* if $\pi^B(p) \geq 0$ for all prices in the support of μ . Because the buyer must break even given his conditional expectation, there is *a priori* no reason to expect that it is sufficient to consider mechanisms that specify deterministic prices, when considering veto-incentive compatible mechanisms.

To summarize, we shall be interested in determining the allocations (x, p) that can be implemented by incentive compatible, individually rational and veto-incentive compatible mechanisms, and in the set of *ex ante* payoffs $\pi = (\pi^B, \pi^S)$ spanned by such allocations.⁹ For short, we refer

⁹A set of allocations $\{(x, p)\}$ *spans* the payoff set $A \subset \mathbb{R}^2$ if the image of that set, by the mappings defined

to this problem as the veto-incentive compatible program, and these allocations as the veto-incentive compatible allocations, to be compared with the *full commitment allocations*, in which the requirement of veto-incentive compatibility is dropped. The problem of determining the latter set is known (see, in particular, Samuelson 1984, and Myerson 1985), and is referred to in the sequel as the full commitment program.

Of particular interest is the (constrained) *efficient* allocation for each program, that is, any allocation (x, p) that maximizes the overall gains from trade $\int_T x(t)[v(t) - c(t)]dt$, or equivalently, that maximizes the sum of *ex ante* payoffs $\pi^S + \pi^B$.

2.3 The Bargaining Game

In Section 3.3, we shall finally consider the infinite-horizon bargaining game. Trivially, this further reduces the set of implementable allocations. Deneckere and Liang (2006) have provided a comprehensive analysis of the game in which the uninformed party, the buyer, makes all the offers. Doing so allows to abstract from signaling issues, since after any history there is only one action that the informed party can take that does not terminate the game. Therefore, the analysis becomes tractable, although far from trivial, and the equilibrium outcome turns out to be unique. We shall consider the opposite case, in which the seller makes all the offers, and show that, in this case as well, it is possible to provide a simple characterization of the equilibrium payoffs as bargaining frictions vanish. Furthermore, the best equilibrium improves upon the equilibrium in the game in which the buyer makes the offers (in terms of efficiency).

Let us define the game formally. Time is discrete, and indexed by $n = 1, \dots, \infty$. At each time or period n , the seller asks a price for the unit. After observing the price, the buyer either accepts or rejects it. If the price is accepted, the game ends. If the offer is rejected, a period elapses and the seller asks for a price again. We shall allow for a public randomization device in the initial period (for concreteness, think of a draw from the uniform distribution on the unit

by (3) and (4), is equal to A .

interval), before the seller sets the first price. This allows us to focus on the extreme points of the equilibrium payoff set, and we shall not refer to this randomization device in the sequel.

The seller's asking price can take any real value. An outcome of the game is a triple (t, n, p_n) , with the interpretation that the realized type is t , and that the buyer accepts the seller's price p_n in period n (which implies that all previous prices were rejected). The case $n = \infty$ corresponds to the outcome in which the buyer rejects all the prices (as a convention, set p_∞ equal to 0). Buyer and seller discount future payoffs at the common discount factor $\delta \in (0, 1)$. The seller's von Neumann-Morgenstern utility function over outcomes is his net surplus $\delta^{n-1}(p_n - c(t))$ when $n < \infty$, and zero otherwise. This suggests the interpretation of the cost as an actual production cost incurred at the time of the transaction, but an alternative and equivalent formulation is that the seller derives a flow utility of $(1 - \delta)c(t)$ in every period in which he holds on to the unit.

The buyer's utility is $\delta^{n-1}(v(t) - p_n)$ when the outcome is (t, n, p_n) , $n < \infty$, and 0 if $n = \infty$.¹⁰ The players' expected utilities over lotteries of outcomes, or *payoffs*, are defined as usual.

A history (of prices) $h^{n-1} \in H^{n-1}$ in case trade has not occurred by time n is a sequence (p_1, \dots, p_{n-1}) of asking prices that the seller set and the buyer rejected (set $H_0 := \emptyset$). A behavior strategy σ^S for the seller is a sequence $\{\sigma_n^S\}$, where σ_n^S is a probability transition from $T \times H^{n-1}$ into \mathbb{R} , mapping the seller's type, the history h^{n-1} into a (possibly random) asking price. A behavior strategy σ^B for the buyer is a sequence $\{\sigma_n^B\}$, where σ_n^B is a probability transition from $H^{n-1} \times \mathbb{R}$ into $\{0, 1\}$, mapping the history h^{n-1} and the outstanding price into a probability of acceptance (as before, "1" denotes acceptance, and "0" rejection). We use the perfect Bayesian equilibrium (PBE) concept as defined in Fudenberg and Tirole (1991, Definition 8.2).¹¹ Given some (perfect Bayesian) equilibrium, we follow standard terminology in calling a seller's offer *serious* if it is accepted by the buyer with positive probability. An offer is *losing* if it is not serious. Clearly, the specification of losing offers in an equilibrium is, to a large extent, arbitrary.

¹⁰Discounting plays no role for optimality. Results carry over to a sequence of short-run buyers, as long as the buyer's payoff is interpreted as the discounted sum of these short-run buyers' payoffs.

¹¹Fudenberg and Tirole define perfect Bayesian equilibria for finite games of incomplete information only. The suitable generalization of their definition to infinite games is straightforward and omitted.

Given some equilibrium $\sigma = (\sigma^B, \sigma^S)$, we denote by $\pi^S(\sigma)$ and $\pi^B(\sigma)$ the *ex ante* payoff of the seller and the buyer, respectively. Note that this involves taking expectations with respect to the seller's type. Given δ , the payoff vector $\pi = (\pi^B, \pi^S)$ can be *achieved* in the bargaining game if there exists an equilibrium σ of the bargaining game such that $\pi = (\pi^B(\sigma), \pi^S(\sigma))$.

Let $E(\delta)$ denote the set of equilibria in the bargaining game with discount factor δ , and $\Pi(\delta) \subset \mathbb{R}^2$ the set of payoff vectors given δ . Further, define $\underline{\Pi} := \liminf_{\delta \rightarrow 1} \Pi(\delta)$ and $\overline{\Pi} := \limsup_{\delta \rightarrow 1} \Pi(\delta)$ as the inner and outer limits of the equilibrium payoff set as frictions vanish. We shall show that those two sets are equal, and provide a simple characterization of this set.

3 Main Results

3.1 Preliminaries: The Full Commitment Program

We start by recalling the characterizations obtained by Samuelson (1984) and Myerson (1985) for the set of *ex ante* payoffs that can be achieved through mechanisms that satisfy incentive compatibility and individual rationality.

For later purposes, it is useful to define the following. Given a mechanism μ , define the expected payment $\bar{p}(t)$ received by type $t \in T$ as

$$\bar{p}(t) := x(t)p(t).$$

Note that specifying the function $\bar{p} : T \rightarrow [0, 1]$ is equivalent to specifying the function p , given our convention that $p(t) = 0$ whenever $x(t) = 0$. Incentive compatibility is the requirement that

$$\pi^S(t) = \bar{p}(t) - x(t)c(t) \geq \bar{p}(s) - x(s)c(t),$$

for all $s, t \in T$. This implies, in particular, that

$$\pi^S(t) \geq \lim_{s \downarrow t} \pi^S(s | t),$$

for all $t \in T$. We refer to these constraints as the set of *local incentive compatibility constraints*.

Suppose that the local incentive compatibility constraints are binding for all $t \in T$.¹² It is then standard to show that π^S has bounded variation and equal to, for all t ,¹³

$$\pi^S(t) = \pi^S(1) + \int_t^1 x(s)dc(s).$$

In this case, all expected payments are uniquely determined by the probabilities of trade (and the price $\bar{p}(1)$) through

$$\bar{p}(t) = \bar{p}(1) - x(1)c(1) + x(t)c(t) + \int_t^1 x(s)dc(s).$$

Let us also define the buyer's payoff $B(t)$ accruing from all seller's types above t , given some allocation (x, p) , as

$$B(t) := \int_t^1 (x(s)v(s) - \bar{p}(s))ds. \quad (5)$$

Note that $B(0) = \pi^B$. Further, if all local incentive compatibility constraints are binding, we can express $B(t)$ as a function of x (and $\bar{p}(1)$) only. Explicitly,

$$\begin{aligned} B(t) &= \int_t^1 [x(s)v(s) - (\bar{p}(1) - x(1)c(1) + x(s)c(s) + \int_s^1 x(u)dc(u))]ds \\ &= \int_t^1 [x(s)(v(s) - c(s)) - \int_s^1 x(u)dc(u)]ds - (1-t)(\bar{p}(1) - x(1)c(1)). \end{aligned}$$

Trivially, given the revelation principle, the set of implementable allocations in the full commitment program is characterized by incentive compatibility and individual rationality. A sharper characterization can be obtained for the set of achievable payoff vectors.

Theorem 1 (*Samuelson 1984, Myerson 1985*)¹⁴ *Assume $c(1) \geq \int_T v(t)dt$. Under full commit-*

¹²Because the cost function need not be continuous, there are allocations that are implementable in the full commitment program for which some local incentive compatibility constraints are not binding.

¹³Here and in what follows, $\int_T x(s)dc(s) := \int_{(0,1)} x(t)c'(t)dt + \sum_{t \in D^c} x(t)(c(t) - \lim_{s \uparrow t} c(s))$, where c' is the derivative of c on each interval, D^c is the set of discontinuities of c , and x is assumed to be right-continuous (since c and v are, this is without loss of generality). Later references to derivatives have to be understood similarly.

¹⁴More precisely, Samuelson (1984, unnumbered lemma) shows that the Pareto-efficient allocations are achieved

ment:

1. The payoff set can be obtained, without loss of generality, by assuming that all local incentive compatibility constraints bind, and that the highest seller type's payoff is zero: $\pi^S(1) = 0$;
2. The payoff set is spanned by the set of non-increasing functions $x : T \rightarrow [0, 1]$ subject to

$$\int_0^1 [x(s)(v(s) - c(s)) - \int_s^1 x(u)dc(u)]ds \geq 0,$$

given expected payments, for all $t \in T$,

$$\bar{p}(t) = x(t)c(t) + \int_t^1 x(s)dc(s).$$

3. The payoff set is a convex polygon whose extreme points are achieved by functions $x : T \rightarrow [0, 1]$ that are step functions with either two or three steps; the origin is an extreme point, and for all other extreme points, it can be assumed that $x(0) = 1$.

The constraint in the second part of the theorem is simply the requirement that $B(0) \geq 0$, given the definition of \bar{p} . The requirement that x be non-increasing ensures incentive compatibility, given the definition of \bar{p} . Theorem 1.2 states that any non-increasing function $x \in [0, 1]$ satisfying $B(0) \geq 0$ (a constraint that only involves x) is part of an allocation that is implementable in the full commitment program, along with the expected payments defined in the theorem, and that these allocations are a sufficient class to generate all the payoffs that can be achieved in this program. As mentioned, one mechanism implementing any such allocation is a mechanism with deterministic prices. There are other mechanisms implementing this allocation, and other allocations that are implementable, but they do not lead to any extra payoff vectors.

In light of this characterization, the payoff set of the full commitment program can be obtained by considering a family of continuous linear programs, in which one maximizes $\lambda \cdot \pi$ over functions x satisfying the constraints given in Theorem 1.2, where $\lambda \in \mathbb{R}^2$ are the (possibly negative)

by two- or three-step functions. Parts 1–2 follows from Myerson's analysis (although all conclusions are rather straightforward given Samuelson's result).

weights on the buyer and seller's payoffs. The maxima of these programs determine the extreme points of the payoff set, and it is then a standard result that such extreme points are themselves achieved by extreme points of the admissible set, *i.e.*, by step functions.

The (constrained) efficient allocation takes a simple form, given that it solves a maximization problem in which the objective and the constraint are linear. As Samuelson and Myerson show, the *ex ante* efficient mechanism is as follows: there exist $0 < t_1 \leq t_2 \leq 1$ such that:

$$x(t) = \begin{cases} 1 & t \in [0, t_1), \\ x & t \in [t_1, t_2], \\ 0 & t > t_2, \end{cases}$$

where

$$x := \frac{t_1 (v_0^{t_1} - c(t_1))}{t_2 c(t_2) - (t_2 - t_1) v_{t_1}^{t_2} - t_1 c(t_1)}, \quad (6)$$

and $v_0^{t_1}$, $v_{t_1}^{t_2}$ are the conditional expectations of the buyer's value over the relevant intervals, namely

$$v_0^{t_1} := \frac{1}{t_1} \int_0^{t_1} v(t) dt, \quad v_{t_1}^{t_2} := \frac{1}{t_2 - t_1} \int_{t_1}^{t_2} v(t) dt.$$

As can be verified, the threshold t_1 (resp., t_2) minimizes (resp., maximizes) the ratio

$$\frac{\int_{t_1}^{t_2} (v(t) - c(t)) dt}{\int_{t_1}^{t_2} t c'(t) dt},$$

given t_2 (resp., t_1). The numerator measures the gains from trade with the types in the interval $[t_1, t_2]$, while the denominator measures the information rents of the seller's types in that interval.¹⁵ Indeed, if the buyer were to trade with, and only with, the seller's types $[0, t]$, his expected gains would be at most

$$Y(t) := \int_0^t (v(s) - c(t)) ds = \int_0^t (v(s) - c(s) - s c'(s)) ds, \quad (7)$$

¹⁵To see this, note that, from the formula for Y given by (7), $\int_{t_1}^{t_2} s c'(s) ds$ is the difference between the gains from trade and the buyer's additional profit accruing from the types $[t_1, t_2]$.

a function that plays an important role in Samuelson and Myerson's analysis, as in ours.

3.2 The Veto-Incentive Compatible Program

Recall that the veto-incentive compatible program is obtained by adding to the full commitment program the requirement that, for any outstanding offer, the buyer's payoff is always non-negative, conditional on the outstanding offer, given his updated beliefs. At first sight, these constraints appear rather intractable, since these are restrictions on the marginal distributions over offers derived from the joint distribution over types and offers that a mechanism defines. The main result of this subsection establishes that, in fact, these constraints can be formulated in terms of the probabilities of trade alone. Therefore, as in the full commitment problem, it is enough to consider functions x , rather than distributions defined by μ , to determine the payoff set, so that standard variational techniques can be applied.

We first characterize implementable allocations, and then achievable payoffs. The following proposition, proved in Section 4, characterizes the set of allocations that can be implemented in the veto-incentive compatible program. Recall that incentive compatibility and individual rationality are minimal requirements.

Proposition 1 *An incentive compatible, individually rational allocation (x, p) is implementable in the veto-incentive compatible program if and only if, for all $t \in T$,*

$$B(t) = \int_t^1 x(s)[v(s) - p(s)]ds \geq 0.$$

Equipped with Proposition 1, it is then straightforward to characterize the set of payoffs that can be achieved in the veto-incentive compatible program.

Theorem 2 *Suppose that $c(1) \geq \int_T v(t)dt$. In the veto-incentive compatible program:*

1. *The payoff set can be obtained, without loss of generality, by assuming that all local incentive compatibility constraints bind, and that the highest seller type's payoff is zero: $\pi^S(1) = 0$;*

2. The payoff set is spanned by the set of non-increasing functions $x : T \rightarrow [0, 1]$ subject to, for all $t \in T$,

$$\int_t^1 [x(s)(v(s) - c(s)) - \int_s^1 x(u)dc(u)]ds \geq 0, \quad (8)$$

given expected payments, for all $t \in T$,

$$\bar{p}(t) = x(t)c(t) + \int_t^1 x(s)dc(s).$$

Note that the constraint in the second part of the theorem is simply the requirement that $B(t) \geq 0$ for all $t \in T$, given the definition of \bar{p} . Theorem 2.2 states that any non-increasing function $x \in [0, 1]$ satisfying $B(t) \geq 0$ for all t (a constraint that only involves the function x) is part of an allocation that is implementable in the veto-incentive compatible program, along with the expected payments defined in the theorem, and that these allocations are a sufficient class to generate all the payoffs that can be achieved in this program. Because of the veto-incentive compatibility constraint, the mechanism that is constructed in the proof of this theorem is not, however, a mechanism with deterministic prices.

The constraints $B(t) \geq 0$ (as stated in Theorem 2.2 in terms of the probabilities $x(t)$ only) are linear (in x) as well. It follows that the payoff set can be once again determined by using continuous linear programming. There is, however, one difficulty that is common to incentive problems with hidden characteristics and a continuum of types, namely the requirement that the function x be non-increasing. Fortunately, tools exist for such constraints. See, in particular, Hellwig (2009). What is the structure of the solution for boundary points of the payoff set? It depends, of course, on the specific boundary point and the underlying functions c and v . Note that, by differentiating twice (8), we obtain that the probability x must satisfy the ordinary differential equation

$$x'(t)(v(t) - c(t)) + x(t)v'(t) = 0$$

on any such interval. The problem then reduces to identifying this finite partition. Indeed,

examples can be constructed for which B is identically zero over some interval, and therefore, the allocation need not be a step function, nor the payoff set a convex polygon (the set of extreme points need not be finite).

It is an easy consequence of this theorem that the payoff vector maximizing the buyer's payoff in the veto-incentive compatible program coincides with the payoff vector that maximizes the buyer's payoff in the full commitment program.¹⁶ The seller's highest payoff is either equal to, or smaller than the corresponding payoff in the full commitment program. Sufficient conditions for equality will be provided in the next section.

3.3 Bargaining Game

We finally consider the bargaining game. Clearly, for any history, given any outstanding offer that is accepted with positive probability, sequential rationality requires that the buyer's conditional payoff from accepting it must be non-negative. Therefore, the *ex ante* payoffs that can be achieved via bargaining must form a subset of the payoff set of the veto-incentive compatible program. But bargaining imposes additional constraints. For instance, since v is non-decreasing, it is common knowledge that the object is worth at least $v(0)$ to the buyer. Therefore, the seller of type t can secure a payoff of $v(0) - c(t)$, since he can always insist on such an offer. (The formal argument is standard and omitted. See, for instance, Fudenberg, Levine and Tirole (1985), Lemma 2, which establishes that no lower offer is ever submitted in equilibrium, so that any such offer is necessarily accepted.) It is worth pointing out here that, if (x, p) is incentive compatible, then $\pi^S(0) \geq v(0) - c(0)$ implies that $\pi^S(t) \geq v(0) - c(t)$ for all $t \geq 0$, so that the aforementioned requirement reduces to $\pi^S(0) \geq v(0) - c(0)$. Since this provides a lower bound on the seller's payoff, we may think of this as the seller's *reservation payoff* in the bargaining game, a strengthening of individual rationality. Note that the most efficient mechanism in the

¹⁶In fact, this follows from Proposition 1 in Samuelson (1984), as he shows that the buyer's favorite outcome is a take-it-or-leave-it offer, so that veto-incentive compatibility does not bind at this allocation.

veto IC program automatically satisfies the reservation payoff constraint.

One might wonder whether bargaining imposes additional restrictions on achievable payoffs. The main result of this section states that this is not the case, at least when $\delta \rightarrow 1$. Before stating this result, note that, with any equilibrium σ and for each type t , one can associate a quantity $x(t)$, namely the discounted total probability with which trade occurs under σ given t ,

$$x(t) = \mathbb{E}_\sigma \left[\sum_n \delta^{n-1} \mathbf{1}_{\sigma_n^B(h^{n-1}, p_n)=1} \right],$$

where $\mathbf{1}_A$ is the indicator function of the event A . Similarly, given some equilibrium σ , we let $\bar{p}(t) \in \mathbb{R}$ denote the expected discounted payment received by type t in this equilibrium. References to local incentive compatibility, or individual rationality, can be understood in terms of the pair (x, \bar{p}) . Recall that $\underline{\Pi} := \liminf_{\delta \rightarrow 1} \Pi(\delta)$ and $\bar{\Pi} := \limsup_{\delta \rightarrow 1} \Pi(\delta)$.

Theorem 3 *Suppose that $c(1) \geq \int_T v(t) dt$. Then $\underline{\Pi} = \bar{\Pi} =: \Pi$. Further, this set of payoff is equal to the set of payoffs that can be achieved by veto-incentive compatible allocations for which*

$$\pi^S(0) \geq v(0) - c(0).$$

This result establishes that the only additional constraint on payoffs imposed by the bargaining game is that the lowest seller's type must secure his reservation payoff. In terms of efficiency, for instance, this theorem implies that there is no difference between the best outcome under bargaining and in the best veto incentive compatible mechanism.

However, it is not true that any individually rational, incentive compatible allocation satisfying veto-incentive compatibility, and giving the lowest seller's type his reservation payoff can be necessarily implemented in the bargaining game. In Section 5.3, we provide an example of such an allocation, and explain why it cannot be implemented. For any such allocation, our result implies that there exists a payoff-equivalent allocation (in terms of *ex ante* payoffs for the seller and the buyer) that can be implemented. Therefore, bargaining imposes restrictions on implementable allocations that go beyond veto-incentive compatibility (and the restriction

imposed by the security payoff), but not on payoffs.

Which constraints bind depends on the vertex of the set Π that is considered. On the upper boundary of this set, it can be assumed, without loss of generality, that all local incentive compatibility constraints are binding, and that the highest type's payoff of the seller trading with positive probability is zero: $\pi^S(1) = 0$; on the other hand, for those vertices that minimize some convex combination of the seller's and buyer's payoff, the incentive compatibility constraints bind "downward," that is, for all $t \in T$,

$$\pi^S(t) = \lim_{s \uparrow t} \pi^S(s | t),$$

with the boundary condition that the trading price of the highest seller's type t is given by the minimum of $v(t)$ and either $\lim_{s \downarrow t} c(s)$, $t < 1$, or $c(1)$ if $t = 1$.

Given that the bargaining game imposes only one additional linear constraint to the veto-incentive compatible program, it can be analyzed via linear programming as well. Depending on c and v , this additional constraint can create a discontinuity (*i.e.*, a step) in the function x which has no counterpart in the previous (veto-incentive compatible) program, and arises before the first binding constraint $B(t) = 0$. Notice also that the constraint that $\pi^S(0) \geq v(0) - c(0)$ implies that the seller secures the *ex ante* payoff $\mathbb{E}[[v(0) - c(t)]^+]$ (because, as already mentioned, it implies that $\pi^S(t) \geq v(0) - c(t)$ for all t). However, the two requirements are not equivalent, as the example in the next subsection illustrates.

The proof of Theorem 3 is sketched in the next section. In doing so, we show that the payoff vector maximizing the seller's payoff, which is also the efficient payoff vector in this set, coincides with the payoff vector maximizing the seller's payoff in the veto-incentive compatible program. That is, as far as efficiency is concerned, bargaining imposes no constraint beyond veto-incentive compatibility. In all three programs, the *ex ante* buyer's payoff is zero in any efficient allocation.

The proof is by construction. This requires us to specify beliefs after out-of-equilibrium offers. While sequential equilibrium is not well-defined in this game (the action space being infinite),

our equilibrium can be made sequential by restricting this action set to a sufficiently rich but finite set of values. In this sense, our choice of off-path beliefs, while dictated by convenience, is not particularly fragile. Refinements just do not have much bite in an environment as rich as ours, and even Markov equilibrium does not appear to narrow down the payoff multiplicity. (A proof of this claim can be found in our online Appendix H, in which we prove that, at least in the case in which there are finitely many types, the equilibrium strategies used in the proofs can be modified so as to be Markovian.)

3.4 Examples and Economic Implications

To illustrate the results, we consider here an example with three types.

Example 4 *The functions v and c are step functions with three steps, and the two discontinuities occur for both functions at $t = 1/3$ and $2/3$. To simplify, we refer to those three types as 1, 2, and 3, assumed to be equally likely. Values and costs are given by*

$$(c_1, c_2, c_3) = (0, 4, 9), \text{ and } (v_1, v_2, v_3) = (2, 5, 12),$$

so that a higher index means a higher value, but also a higher cost. The left panel of Figure 1 represents the three payoff sets. The largest area is the set of payoffs in the full commitment case, and the smallest payoff set is the equilibrium payoff set in the bargaining game as $\delta \rightarrow 1$. In between lies the set of veto-incentive compatible payoff vectors. By changing only one parameter, namely, by increasing v_2 from 5 to 10, the payoff sets change considerably. See right panel. The two points $(440/1323, 20/63)$ on the left, and $(56/243, 2/9)$ on the right, represent the unique equilibrium payoff vectors in the bargaining game in which the (uninformed) buyer makes the offers in every period, as characterized in Deneckere and Liang (2006; “DL” in the figure) for $\delta \rightarrow 1$. As is clear, this (buyer-proposing) equilibrium payoff need not lie in the set of (seller-proposing) equilibrium payoff vectors, although it achieves a lower surplus than the maximum joint surplus when the seller makes offers. This is no coincidence, see below.

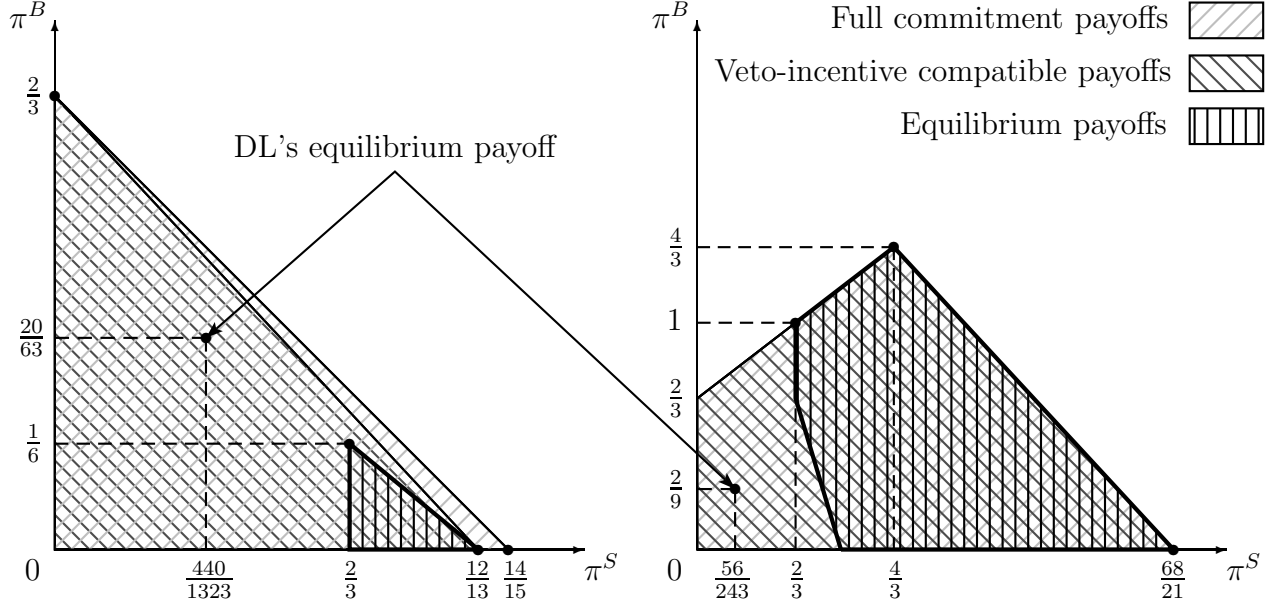

Figure 1: Full commitment, Veto-Incentive Compatible, and Limiting Equilibrium Payoff Sets.

This example illustrates several points that hold more generally. First, as mentioned, the buyer's highest payoff coincides in the veto-incentive compatible and the full commitment programs, but clearly, it might be lower in the equilibrium of the bargaining game. More importantly, the seller's highest payoff coincides in the bargaining game and the veto-incentive compatible program. This highest payoff, however, might fall short of the highest payoff in the commitment program.¹⁷

When is (constrained) efficiency possible under bargaining, *i.e.*, when is veto-incentive compatibility consistent with efficiency? Obviously, this is trivially the case if the optimal allocation under full commitment is such that no seller's type trades with interior probability. If some seller's types do trade with interior probability, sufficient conditions can be given in terms of the buyer's gain function Y (see (7)). Because $Y(0) = 0$ and $Y'(0) > 0$, yet $Y(1) < 0$, Y admits a

¹⁷Note also that, as is clear from the left panel, the restriction on achievable payoffs imposed by the lowest seller's type reservation payoff is not equivalent to the restriction that the seller obtains the *ex ante* payoff $\mathbb{E}[[v(0) - c(t)]^+] = 2/3$. Consider the vertex that minimizes the seller's payoff, subject to the buyer's payoff being zero. The requirement that the seller's lowest type gets at least $v(0) - c(0)$ drives the seller's *ex ante* payoff up to $17/18 > 2/3$. In this example, driving the seller's *ex ante* payoff down to $\mathbb{E}[[v(0) - c(t)]^+]$ is only possible in some equilibrium for high enough values of the buyer's payoff.

smallest local maximizer \underline{t} . Note that \underline{t} solves $v(\underline{t}) - c(\underline{t}) = \underline{t}c'(\underline{t})$ (assuming differentiability at this point for the sake of this discussion). Let also \bar{t} denote the smallest strictly positive root of Y . We show in the online appendix (Appendix D) that efficiency is attainable in bargaining if

$$\forall t \geq \bar{t} : \int_{\underline{t}}^t (v(s) - c(t)) ds \geq 0. \quad (9)$$

Obviously, as our example above shows (left panel), it is not always true that efficiency can be achieved. Note that the condition becomes easier to satisfy as gains from trade ($v(t) - c(t)$) increase, and information rents ($tc'(t)$) decrease (both \underline{t} and \bar{t} then increase). We summarize this discussion as follows.

Constrained efficiency can be achieved by bargaining as $\delta \rightarrow 1$ (even when the first-best outcome cannot) if gains from trade are high, or information rents low enough.

As an illustration, we consider Samuelson's Example 1, in which $c(t) = t$, and $v(t) = kt + \Delta$, where $k, \Delta \geq 0$. (This example subsumes both Akerlof's linear example ($\Delta = 0$) and the uniform additive example ($k = 1$) of Myerson, 1985.) See Figure 2 and Appendix G for details on Condition (9) in this example. Gains from trade require that $\Delta > 1 - k$, an area to which we can restrict attention. When $k \geq 2$ or $\Delta \geq 1 - k/2$ (Area B), the first-best is implementable in the veto-incentive compatible (and *a fortiori* in the full commitment) program. In Area A, when $\Delta \geq \frac{4}{4-k} - k$, Condition (9) is satisfied. In particular, in Area A, the first-best is not implementable under full commitment, but imposing veto-incentive compatibility comes at no additional cost. In the remaining area (for $\Delta \in [1-k, 4/(4-k)-k)$), Condition (9) is not satisfied, yet the conclusion remains valid: veto-incentive compatibility comes "for free." This suggests that veto-incentive compatibility is a relatively weak constraint (but also that the linear-additive example is somewhat misleading, cf. Example 4). Furthermore, we see that, whether considering the actual boundary defining when veto-incentive compatibility can be satisfied ($\Delta = 1 - k$),

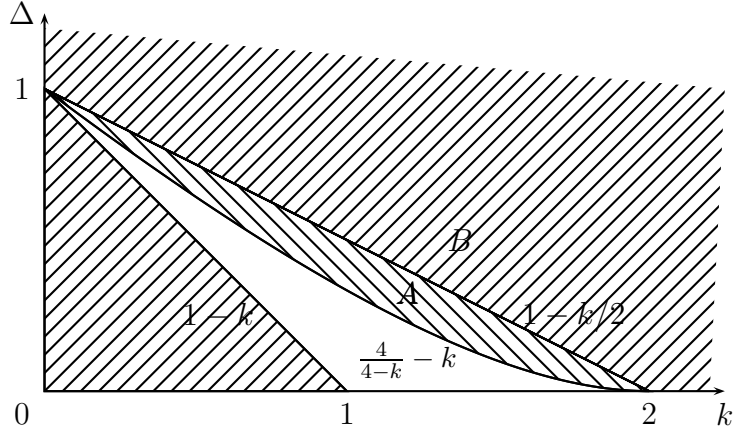

Figure 2: Sufficient conditions in Samuelson's Example 1.

or the boundary computed according to (9), higher gains from trade make it more likely to be fulfilled.

Because bargaining can achieve the same degree of efficiency as any (incentive compatible, individually rational) mechanism that satisfies veto-incentive compatibility, this implies that market institutions may only improve upon bargaining if they constrain the buyer somehow, in a way that weakens the veto-incentive compatibility constraint. This seems rather demanding, but not impossible. For instance, screening contracts by the uninformed party (here, the buyer), as in Rothschild and Stiglitz (1976), dispense with the requirement of veto-incentive compatibility: the uninformed party offers (and commits) to a menu of price and quantity pairs, and the informed party chooses from them. This is not quite as demanding in terms of commitment as full commitment, although the difference is small (see Mylovanov, 2008). In any event, there is little to gain from less constraining trading institutions. Note, for instance, that communication will not expand the set of equilibrium outcomes. (Formally, the set of allocations that are achieved by communication equilibria is the same as those achieved by perfect Bayesian equilibria in the bargaining game, as $\delta \rightarrow 1$). Fortunately, as discussed, circumstances in which veto-incentive compatibility does not reduce efficiency are quite common, and in those circumstances, as little

commitment as bargaining suffices.

How do equilibrium outcomes in bargaining compare with the unique equilibrium outcome derived by Deneckere and Liang, when the buyer makes all the offers? In our two examples, the seller does worse in the latter equilibrium outcome than in any equilibrium outcome of our game. However, it is easy to construct examples in which this is not the case. In fact, the following can be shown (details available upon request).

Lemma 1

- i. The allocation from the unique limit equilibrium outcome of the game in which the buyer makes all the offers is an equilibrium allocation in the game in which the seller makes all the offers if and only if it gives the lowest seller's type his reservation payoff (i.e., $v(0) - c(0)$), provided that the discount factor is sufficiently close to one.*
- ii. For δ close enough to one, the game in which the seller makes all the offers admits an equilibrium outcome that is strictly more efficient than the limit equilibrium outcome of the game in which the buyer makes all the offers.*

The first statement should come as no surprise given that the allocation that results from the bargaining game in which the buyer makes all the offers must be veto-incentive compatible. This follows from the “skimming” property in bargaining: because, from any history onward, the remaining seller’s types are all types above some threshold z_n , and because the buyer’s continuation payoff must be non-negative, it must be that $B(z_n) \geq 0$.¹⁸

The second statement is immediately implied by the first, given that the buyer secures a strictly positive payoff when he makes the offers, yet within the set of veto-incentive compatible allocations, efficiency is maximized when the buyer gets zero profits.

¹⁸If z_n and z_{n+1} denote consecutive threshold types, the inequality $B(t) \geq 0$ for $t \in (z_n, z_{n+1})$ follows from the fact that the types in $[z_n, t]$ are the most unprofitable ones (for the buyer) above z_n .

Of course, this lemma compares the best equilibrium outcome in one game with the unique equilibrium outcome in the other. There might be equilibria in the game in which the seller makes all the offers that are more inefficient than the equilibrium outcome when the buyer makes offers. Rather surprisingly, our example illustrates that this need not be true, however. As is obvious from the right panel of Figure 1, efficiency might be necessarily higher when the seller makes all the offers. This makes apparent that having the seller make all the offers does not simply “expand” the set of equilibria.

4 Main Proofs

4.1 Proof of Proposition 1 and Theorem 2

The proof of Theorem 2 will be divided in several steps. First, we establish Proposition 1, which immediately implies Theorem 2.2, given Theorem 1. We will then show how this, along with some other observations, can be used to establish Theorem 2.1.

The proof of Proposition 1 is itself divided into three parts. First, we show that, given an allocation (x, p) , the condition that $B(t)$ be non-negative for all t is necessary for the allocation to be implementable in the veto-incentive compatible program. Second, we turn to sufficiency. We first show that the conditions are sufficient if the functions c and v are step functions. Then we show how, by appropriate limiting arguments, the result follows for any functions c and v satisfying the assumptions of the model. For the sake of concision, we relegate the second and third part to an appendix (online Appendix A); but the gist of the idea can be conveyed in the simple case in which cost and value functions are step functions with two steps only, and that this is what is done in Lemma 3 below.

4.1.1 Proof of Proposition 1

First comes necessity.

Lemma 2 *If (x, p) is an allocation that is implementable in the veto-incentive compatible program, then, for all $t \in T$,*

$$B(t) = \int_t^1 (x(s)(v(s) - p(s))ds \geq 0.$$

Proof. Fix an allocation (x, p) that is implementable in the veto-incentive compatible program, and let μ denote the corresponding mechanism. Observe that, for all $t \in T$,

$$\begin{aligned} \int_t^1 x(s)p(s)ds &= \int_t^1 \int_{\mathbb{R}_+} p\mu(s)[1, dp]ds \\ &\leq \int_t^1 \int_{\mathbb{R}_+} \left(\int_T v(u)d\nu(u | p) \right) \mu(s)[1, dp]ds \\ &\leq \int_t^1 \int_{\mathbb{R}_+} \frac{\int_{u \geq t} v(u)d\nu(u | p)}{\nu([t, 1] | p)} \mu(s)[1, dp]ds \\ &= \int_t^1 x(s)v(s)ds. \end{aligned}$$

The first equality follows from the definition of the function p (see (2)). The first inequality is implied by veto-incentive compatibility; the second follows from the monotonicity of v ;¹⁹ the last equality, from the law of iterated expectations. This establishes the claim. ■

We now show sufficiency in the special case in which c and v are step functions with only one jump. As mentioned, the complete proof is in online Appendix A.

Lemma 3 *Suppose that c and v are step functions with a unique discontinuity point at $\hat{t} \in (0, 1)$. Consider the allocation (x, p) defined by*

$$x(t) = \begin{cases} x_1 & \text{if } t < \hat{t} \\ x_2 & \text{if } t \geq \hat{t} \end{cases} \quad p(t) = \begin{cases} p_1 & \text{if } t < \hat{t}, \\ p_2 & \text{if } t \geq \hat{t}. \end{cases}$$

¹⁹That is, with the understanding that the integrand is zero when $\nu([t, 1] | p) = 0$.

Suppose that (x, p) is implementable in the full commitment program, and for every $t \in T$,

$$B(t) = \int_t^1 (x(s)(v(s) - p(s))ds \geq 0.$$

Then (x, p) is also implementable in the veto-incentive compatible program.

Let v_1 and $v_2 \geq v_1$ denote the two values that the function v takes. The hypothesis that $B(t) \geq 0$ for every $t \in T$ implies that $v_2 \geq p_2$ and

$$\hat{t}x_1(v_1 - p_1) + (1 - \hat{t})x_2(v_2 - p_2) \geq 0.$$

Incentive compatibility implies that $x_1 \geq x_2$ and $p_1 \leq p_2$. It follows that there exists $z \in \left[0, \frac{x_2}{x_1}\right]$ such that

$$zx_1p_1 + (x_2 - zx_1)v_2 = x_2p_2. \tag{10}$$

To see this, notice that for $z = 0$, the left-hand side reduces to x_2v_2 , which is (weakly) larger than the right-hand side. On the other hand, for $z = \frac{x_2}{x_1}$, the left-hand side reduces to x_2p_1 , which is (weakly) smaller than the right-hand side.

Consider now the following random mechanism. When the seller announces a low type (*i.e.*, a type smaller than \hat{t}), the buyer receives the offer p_1 with probability x_1 (with probability $1 - x_1$ no offer is made and there is no trade). When the seller announces a high type, the buyer receives the offer p_1 with probability zx_1 and the offer v_2 with probability $x_2 - zx_1$ (again, there is no trade with the remaining probability).

It is immediate to check that the above mechanism implements the allocation (x, p) . Consequently, it satisfies the seller's incentive compatibility and individual rationality constraints. We now show the mechanism also satisfies the buyer's veto incentive compatibility constraints. Notice that the buyer receives the offer v_2 only if the seller's type is high. Clearly, the buyer is willing to accept that offer. Finally, suppose that the buyer receives the offer p_1 . His expected

payoff (conditional on p_1) is equal to

$$\frac{1}{\hat{t}x_1 + (1 - \hat{t})zx_1} [\hat{t}x_1(v_1 - p_1) + (1 - \hat{t})zx_1(v_2 - p_1)].$$

We multiply the above expression by $\hat{t}x_1 + (1 - \hat{t})zx_1$ and add and subtract $(1 - \hat{t})x_2(v_2 - p_2)$ to obtain

$$\begin{aligned} \hat{t}x_1(v_1 - p_1) + (1 - \hat{t})x_2(v_2 - p_2) - (1 - \hat{t})x_2(v_2 - p_2) + (1 - \hat{t})zx_1(v_2 - p_1) = \\ \hat{t}x_1(v_1 - p_1) + (1 - \hat{t})x_2(v_2 - p_2) \geq 0, \end{aligned}$$

where the equality follows from the definition of z in (10). We conclude that the buyer is also willing to accept the offer p_1 and the allocation (x, p) is implementable in the veto-incentive compatible program.

4.1.2 Proof of Theorem 2.1

To establish Theorem 2.1, it remains to show that the payoff set of the veto-incentive compatible program can be obtained by assuming that:

1. all local incentive compatibility constraints are binding;
2. the highest type of the seller that trades with positive probability has a zero payoff;
3. the lowest type of the seller trades with probability 1, that is $x(0) = 1$.

Let us refer to the resulting payoff set as Π^V . Note that this set is compact and convex. These three claims are established by considering the boundary of Π^V . Because both properties are preserved under convex combinations, the result follows for the entire set. The details are somewhat tedious and also relegated to Appendix A.

4.2 Proof of Theorem 3

This theorem is proved by considering the set of extreme points of the payoff set, distinguishing them according to whether an extreme point lies to the “north-east,” “north-west,” or “south-west” (*i.e.*, according to the signs of the weights on the seller’s and buyer’s payoff whose linear combination this extreme point maximizes). Arguments for one case require minor modifications for the other cases.²⁰ For brevity, we only provide the complete proof for the case of positive weights, that is, we consider extreme points that lie on the Pareto-frontier.

The proof is divided into two steps. First, we show how allocations for which x is a step function satisfying some properties can be implemented as equilibria. Second, we show that every vertex of the equilibrium payoff set is the limit of a sequence of such allocations.

4.2.1 Regular Allocations

We first define a class of allocations (x, p) . Recall that, for $t_1 < t_2$, $v_{t_1}^{t_2} := \mathbb{E}[v(t) \mid t \in [t_1, t_2]]$.

Definition 1 *The allocation (x, p) is regular if there exist $0 = t_0 < t_1 < \dots < t_K \leq 1$, for some finite K , such that:*

1. *For some thresholds $1 = x_1 > \dots > x_K > 0$,*

$$x(t) = \begin{cases} x_k & \text{if } t \in [t_{k-1}, t_k), \quad k = 1, \dots, K, \\ 0 & \text{if } t \geq t_K; \end{cases}$$

2. *For some prices $v(0) \leq p_1 < \dots < p_K$,*

$$p(t) = \begin{cases} p_k & \text{if } t \in [t_{k-1}, t_k), \quad k = 1, \dots, K, \\ 0 & \text{if } t \geq t_K; \end{cases}$$

3. *For each $k = 1, \dots, K - 1$,*

²⁰For instance, in the “south-west” region, the local incentive constraints are binding “downward,” and the definition of regular allocations must be modified accordingly.

$$x_k(p_k - c(t_{k,-})) = x_{k+1}(p_{k+1} - c(t_{k,-})),$$

where $t_{k,-} = \lim_{t \uparrow t_k} t$, and $x_K(p_K - c(t_{K-})) \geq 0$;

4. Furthermore, we have $B(0) \geq 0, B(t_1) = \dots = B(t_{K-2}) = 0$, and $B(t_{K-1}) > 0$;

5. Finally, $v_{t_{K-2}}^{t_{K-1}} > c(t_{K-1,-})$.

That is, a regular allocation is a step allocation such that local incentive compatibility constraints hold at each jump, the contribution to the buyer's payoff of each interval of types $[t_k, 1]$ is zero except for $k = 0, K - 1$, and positive for $t = 0, K - 1$ (strictly so for $t = K - 1$). Furthermore, the expected valuation of the buyer over the penultimate interval of types exceeds the cost of the seller's highest type in the previous interval, and the seller's lowest type must guarantee his security payoff.

Regular allocations are perfect candidates for equilibrium outcomes: one may think of each jump as defining an *interim* allocation (truncated according to the jumps) that satisfies incentive compatibility (for the seller) and individual rationality for the buyer at every step, as well as (by (1) and (2)) for the seller *ex ante*. In addition, regular allocations span a rich set of payoff vectors, as we will show that we can approximate every extreme point of the payoff set by a sequence of payoffs of regular allocations.

But a regular allocation need not be an equilibrium allocation in the discrete-time game, because of the indivisibilities that discrete periods introduce. This indivisibility becomes less and less problematic as $\delta \rightarrow 1$, and we show that we can choose (x^δ, p^δ) such that

$$\|(x^\delta, p^\delta)\| \rightarrow \|(x, p)\|,$$

uniformly in t , as $\delta \rightarrow 1$. The following lemma will be established in the next two subsections.

Lemma 4 *Fix a regular allocation (x, p) . There exists a sequence of $\sigma^\delta \in E(\delta)$ such that the corresponding sequence of allocations (x^δ, p^δ) converges to (x, p) as $\delta \rightarrow 1$, uniformly in t .*

In what follows, we consider regular allocations with $K > 2$ and $v_{t_{K-2}}^{t_{K-1}} > v(0)$ (notice that the last condition is automatically satisfied by regular allocations with $K > 3$). This simplifies the notation since we are able to show that for δ sufficiently large the regular allocation (x, p) is an equilibrium allocation (*i.e.*, we have exact implementation). The proof for the remaining cases is very similar, but requires additional notation (in such cases we only have approximate implementation). We first establish some properties that regular allocations satisfy and then present the equilibrium of the bargaining game.

4.2.2 Properties of Regular Allocations

It follows from $B(t_{K-2}) = 0$, $B(t_{K-1}) > 0$ and $p_K > p_{K-1}$, that $v_{t_{K-2}}^{t_{K-1}} < p_{K-1} < v_{t_{K-2}}^{t_K}$. Thus, there exists a unique $\beta \in (0, 1)$ such that

$$p_{K-1} = \beta v_{t_{K-2}}^{t_K} + (1 - \beta) v_{t_{K-2}}^{t_{K-1}}. \quad (11)$$

Using $B(t_{K-2}) = 0$, $v_{t_{K-2}}^{t_{K-1}} > c(t_{K-1}, -)$ and the incentive compatibility constraint

$$x_{K-1} (p_{K-1} - c(t_{K-1}, -)) = x_K (p_K - c(t_{K-1}, -)),$$

it is easy to show that β also satisfies

$$x_K - x_{K-1}\beta = x_{K-1} (1 - \beta) \left(\frac{v_{t_{K-2}}^{t_{K-1}} - c(t_{K-1}, -)}{v_{t_{K-1}}^{t_K} - c(t_{K-1}, -)} \right) > 0,$$

and

$$x_{K-1}\beta v_{t_{K-2}}^{t_K} + (x_K - x_{K-1}\beta) v_{t_{K-1}}^{t_K} = x_K p_K$$

As the last step in the proof of Lemma 4, we show that the allocation (x, p) can be implemented in the bargaining game when the discount factor δ is sufficiently large.

4.2.3 The equilibrium σ^δ of the bargaining game

First, we describe the players' on-path behavior. Then we turn to the off-path behavior.

The behavior of the types in the intervals $[t_0, t_1)$ and $[t_K, 1]$ is very simple. In the first period of the game, the seller's types in $[t_0, t_1)$ make the offer p_1 and the buyer accepts it. In every period $n = 1, 2, \dots$, the types in $[t_K, 1]$ make the losing offer $v(1)$ and the buyer rejects it.

Consider now the types in the interval $[t_{k-1}, t_k)$, $k = 2, \dots, K-2$. In each period $n = 1, 2, \dots$, they make the offer p_k . In each period, the buyer accepts the offer p_k with probability $\psi_k = \frac{x_k(1-\delta)}{1-x_k\delta}$. Therefore, the discounted probability that the offer p_k is accepted is equal to

$$\psi_k + \delta(1 - \psi_k)\psi_k + \delta^2(1 - \psi_k)^2\psi_k + \dots = x_k.$$

The remaining types to consider are those in the last two intervals. Let \hat{n} denote the integer that satisfies²¹

$$\delta^{\hat{n}+2} \leq x_{K-1} < \delta^{\hat{n}+1}.$$

Also, let $\hat{\beta} \in (0, 1)$ be such that $\delta^{\hat{n}}\hat{\beta} = x_{K-1}\beta$.

The types in $[t_{K-2}, t_{K-1})$ and the types in $[t_{K-1}, t_K)$ adopt the same behavior in the first \hat{n} periods of the game. In particular, in period $n = 1, \dots, \hat{n} - 1$ they all make the losing offer $v(1)$ which the buyer rejects. In period \hat{n} , these type make the offer $v_{t_{K-2}}^{t_K}$. The buyer accepts this offer with probability $\hat{\beta}$.

If the buyer rejects the offer $v_{t_{K-2}}^{t_K}$ in period \hat{n} , then the types in the two intervals behave differently. In each period $\hat{n} + 1, \hat{n} + 2, \dots$, the types in $[t_{K-2}, t_{K-1})$ make the offer $v_{t_{K-2}}^{t_{K-1}}$. In each period, the buyer accepts this offer with probability ψ_{K-1} . This probability is such that

$$x_{K-1} = \delta^{\hat{n}} \left(\hat{\beta} + (1 - \hat{\beta}) \delta \left(\frac{\psi_{K-1}}{1 - \delta(1 - \psi_{K-1})} \right) \right).$$

²¹Notice that \hat{n} is well defined for δ sufficiently close to one.

Notice that $\psi_{K-1} \in (0, 1)$ since $\delta^{\hat{n}+1} > x_{K-1}$. Furthermore

$$\lim_{\delta \rightarrow 1} \frac{\psi_{K-1}}{1 - \delta(1 - \psi_{K-1})} = 1. \quad (12)$$

Finally, in each period $\hat{n} + 1, \hat{n} + 2, \dots$, the types in $[t_{K-1}, t_K)$ make the offer $v_{t_{K-1}}^{t_K}$. The buyer accepts each offer with probability ψ_K which is chosen to satisfy

$$x_K = \delta^{\hat{n}} \left(\hat{\beta} + (1 - \hat{\beta}) \delta \left(\frac{\psi_K}{1 - \delta(1 - \psi_K)} \right) \right).$$

Again, $\psi_K \in (0, 1)$ since $x_K > x_{K-1}\beta$ and $\delta^{\hat{n}+1} > x_{K-1} > x_K$.

Notice that if both players follow the behavior that we have just described, then each type $t \in [t_{k-1}, t_k)$, $k = 1, \dots, k$, trades the good with discounted probability equal to x_k and receives the discounted expected transfer $x_k p_k$.²² In other words, the players' behavior implements the regular allocation (x, p) .

To see that this behavior is part of an equilibrium, consider all possible deviations in turn. First, we analyze the buyer's deviations. Notice that there is only deviation which is detectable and that, at the same time, does not end the game. This happens when the buyer rejects the offer p_1 in the first period. Then the types in $[t_0, t_1)$ keep making the same offer p_1 until the buyer accepts it. On the other hand, the buyer accepts the serious offer p_1 in the first period in which is made. Finally, suppose that the buyer deviates when he is supposed to randomize. Then, following this deviation (which is not detectable), he goes back to the behavior described above.

Consider now the seller's deviations. The buyer accepts an off-path offer if and only if the offer is weakly smaller than $v(0)$. Following an off-path history of offers, type t of the seller offers $v(0)$ in every future period if $v(0) \geq c(t)$. Otherwise type t offers $v(1)$ in every future period.

It is simple to verify that the strategy profile just described constitutes an equilibrium (or

²²As mentioned above, the types above t_K do not trade the good and do not receive a transfer.

rather, that there exists a belief system along which this strategy profile is an equilibrium) when δ is sufficiently large. By construction, each type t , prefers his own strategy to the strategy of type t' . Thus, any type $t \in [0, 1]$ does not have any incentive to mimic the equilibrium behavior of another type t' . Also, type t does not have any incentive to deviate and make an off-path offer strictly larger than $v(0)$ (the offer would be rejected) or strictly smaller than $v(0)$ (the type would be strictly better off by making the off-path offer $v(0)$). Finally, it follows from equality (12), from the condition $v_{t_{K-2}}^{t_{K-1}} > v(0)$, and from the incentive compatibility constraints that for δ sufficiently close to one, no type has an incentive to deviate and make the off-path offer $v(0)$.

Conditional on receiving the offer p_1 in the first period, the buyer's expected payoff is weakly positive. Thus, he has an incentive to accept the offer. Conditional on receiving any other on-path offer, the buyer's expected payoff is zero. Therefore it is optimal to randomize.

The off-path behavior can be easily made sequentially rational by assuming that following any deviation the buyer assigns probability one to the event that the seller's type is $t = 0$. (This might be seen as an extreme belief revision, but it is convenient, and other possibilities would do just as well.)

4.2.4 Proof of Theorem 3, Conclusion

The previous subsections have shown that any regular allocation can be achieved as an equilibrium allocation in the bargaining game as $\delta \rightarrow 1$. Note that the set of equilibrium payoffs that can be achieved in the bargaining game is a subset of the set of payoffs spanned by the allocations described in Theorem 3, because the constraint $\pi^S(0) \geq v(0) - c(0)$ must hold, as explained before the theorem. Also, equilibrium allocations must satisfy veto-incentive compatibility. Therefore, one direction of the Theorem 3 is obvious. The other direction will be established if we can show that every extreme point of the set of veto-incentive compatible payoffs giving the seller his security payoff can be approximated arbitrarily closely by regular allocations. This is the content of Lemma 5. Recall that, for brevity, we restrict ourselves here to the case of extreme points

of the payoff set that lie on the Pareto-frontier. The following is proved in the online appendix (Appendix B). This Appendix also shows how the result extends to the case of a finite (rather than infinite) horizon. The following lemma concludes the proof of Theorem 3.

Lemma 5 *For every extreme point (π^S, π^B) (on the north-east boundary) of the payoff set that can be achieved by veto-incentive compatible allocations for which $\pi^S(0) \geq v(0) - c(0)$, and every $\varepsilon > 0$, there exists a regular allocation whose payoff is within distance ε of (π^S, π^B) .*

5 Extensions

This section addresses three issues. First, we show that veto-incentive compatibility is implied by standard bargaining protocols (Section 5.1), as mentioned in the introduction. Second, we discuss the impact of imposing similar requirements on the seller's side (Section 5.2). Modern commercial law emphasizes buyer's rights. It is then natural to ask whether this is compatible with protection of the seller, and whether mechanisms can be found that are agreeable to both the buyer *and* the seller not only *ex ante*, but also *ex interim*.

Finally, in Section 5.3, we dwell on an important qualification to our analysis. Our results characterize those *ex ante* payoffs that can be achieved under different levels of commitment. These characterizations do not carry over from payoffs to allocations, as we explain.

5.1 Bargaining Outcomes Satisfy Veto-Incentive Compatibility

Veto-incentive compatibility is not only sensible from a practical point of view, it can also be shown to be automatically satisfied by most bargaining protocols that appear in the literature. This is formally established here. We define bargaining games satisfying the following extensive forms: (i) Nature selects one party to make an offer at the first stage $n = 0$ (independently of the type). This party offers a price $p \in \mathbb{R}$, whereupon the other party decides to accept it or not. If the other party accepts and the seller's type is t , then the buyer obtains a payoff

$v(t) - p$, whereas the seller obtains a payoff $p - c(t)$. If the offer is rejected, Nature ends the game with probability $\theta(h^1)$, where h^1 is the public history. If the game does not end, nature determines that the buyer makes an offer with probability $\chi(h^1)$ and the seller makes an offer with probability $1 - \chi(h^1)$. The game proceeds accordingly. The non-increasing sequence $\{\delta_n\}_{n \geq 0}$ determines the common discount factor of period n (as evaluated from period 0, *e.g.*, in the case of geometric discounting, $\delta_n = \delta^n$). We normalize δ_0 to 1 and assume continuity at infinity, $\lim_{n \rightarrow \infty} \delta_n = 0$. Notice that our protocol encompasses alternate-offers protocols, protocols in which the buyer makes all the offers as well as finite-horizon protocols (set $\delta_n = 0$ for all $n > T$). Any such extensive form, alongside the incomplete information and the utility function, defines a multi-stage game of observed actions. We define perfect Bayesian equilibria of such a game and the corresponding allocation as in Section 3.3. Proposition 2 proves that any equilibrium of the bargaining game satisfies veto-incentive compatibility. (See Online Appendix F for a proof.)

Proposition 2 *Any perfect Bayesian equilibrium allocation satisfies veto-incentive compatibility.*

5.2 Limited Commitment on the Seller’s Side

Veto-incentive compatibility weakens the commitment assumption made in the full commitment program on the buyer’s side. As discussed, this is a relaxation that is relevant for many actual market institutions. Furthermore, our characterization of the equilibrium payoffs in the bargaining game suggests that this is the “right” relaxation, namely, the absence of commitment on either side, as captured by the bargaining game, appears to impose no further constraints on achievable payoffs, aside from the security payoff that the seller must secure.²³

It is then natural to ask whether one could derive results that mirror those of Section 3.2 in which the seller’s commitment, instead of, or in addition to, the buyer’s commitment is relaxed.

²³Of course, in bargaining, the seller is not formally allowed to withdraw an offer that he makes, but why would he? Acceptance by the buyer reveals no information, so a seller that anticipates withdrawing an offer might as well not submit it.

While we shall not attempt to obtain a characterization for each possible case, we discuss here the relationship between the different sets of allocations and payoffs. As we shall see, limited commitment on the seller's side is arguably less of a problem than on the buyer's side.

Unlike the buyer, the seller gets an opportunity to influence the terms at which the trade would take place. Therefore, there are two possible ways of modeling the absence of commitment on the seller's side. A mechanism is *ex post* individually rational for the seller if the price p that is offered to the buyer is always higher than the cost of the seller's reported type t :

$$\forall t \in T : \int_{[0, c(t))} \mu(t)[1, dp] = 0.$$

This guarantees that the seller never loses from the mechanism, but it does not give him the authority to actually prevent the trade. Alternatively, we might endow the seller with the ability to block the trade given the realized price. This notion, in line with Forges' original definition of veto-incentive compatibility, is more demanding than *ex post* individual rationality: the ability to block the trade affects the seller's incentives to report his type truthfully, as the payoff from making a given report must include the option value from blocking the trade if the realized price happens to be below the seller's actual cost. To be more formal, we re-define the payoff of the type t seller that reports s , from a given mechanism μ , as

$$\hat{\pi}^S(s | t) = \int_{\mathbb{R}_+} \mathbf{1}_{\{p \geq c(t)\}}(p - c(t)) \mu(s)[1, dp].$$

A mechanism is *seller veto-incentive compatible* if it is incentive compatible given the payoff $\hat{\pi}$, and the allocation (x, p) is implementable in the seller's veto-incentive compatible program if there is a mechanism that is seller veto-incentive compatible and induces the allocation (x, p) , according to (1)–(2), taking into account that trade does not take place for prices below $c(t)$. To distinguish this notion from veto-incentive compatibility as defined in Section 2, the latter will now be referred to as buyer veto-incentive compatibility.

Does seller veto-incentive compatibility, or even *ex post* individual rationality restrict the set

of implementable allocations, or the set of achievable payoff vectors? In a nutshell, the answer is no, as far as payoffs are concerned, and sometimes, as far as allocations are concerned, but only if it comes in addition to buyer veto-incentive compatibility. Formally:

Proposition 3

- i. The set of implementable allocations (and thus, of achievable payoff vectors) in the full commitment program remains unchanged if seller veto-incentive compatibility is imposed.*
- ii. The set of implementable allocations (and thus, of achievable payoff vectors) in the buyer veto-incentive compatible program remains unchanged if seller ex post individual rationality is imposed.*
- iii. The set of achievable payoff vectors in the buyer veto-incentive compatible program remains unchanged if seller veto-incentive compatibility is imposed.*

Because seller veto-incentive compatibility implies seller *ex post* individual rationality, we have omitted some relationships that follow from the proposition. For instance, from (i), it follows that seller *ex post* individual rationality does not restrict the set of implementable allocations in the full commitment program. Furthermore, all remaining inclusions are strict: that is, for some parameters, the set of implementable allocations in the buyer veto-incentive compatible program is strictly reduced if seller veto-incentive compatibility is imposed, and, as we know, the set of implementable allocations in the veto-incentive compatible program is strictly contained in the set of allocations of the full commitment program, for some parameters.

The proofs of the claims in Proposition 3, some of which follow arguments that are similar to the other proofs in the paper, are sketched in the online appendix (Appendix E).²⁴ Additional details, as well as examples establishing the strict inequalities, are available from the authors.

²⁴More precisely, we show in Appendix E that seller *ex post* individual rationality does not restrict the set of allocations that can be achieved in the (buyer) veto-incentive compatible program, and that, as far as payoffs are concerned, we can also impose seller veto-incentive compatibility. In both cases, attention is restricted to finite types, and the result in the general case follows by standard limiting arguments.

5.3 Payoffs vs. Allocations

Our characterization of veto-incentive compatibility and equilibrium outcomes in the bargaining game were cast in terms of the agents' expected payoffs, not in terms of allocations. For some important criteria, this makes no difference: the efficient payoff, the buyer's highest payoff, for instance, are implemented by a unique allocation. However, our result does not extend to allocations in general. *Not every incentive-compatible allocation whose payoffs satisfy the conditions of the characterization is implementable.* For instance, not every allocation that gives the seller's lowest type a profit $\pi^S(0) \geq v(0) - c(0)$ need be implementable. Suppose that there are three equiprobable types of seller (and buyer), and consider parameters such that the highest cost, c_3 , is lower than the expected value of the lower two values, $(v_1 + v_2)/2$. Further, consider an incentive compatible allocation in which the buyer's expected payoff is 0, the highest seller's type does not trade, but the second highest does; this seller's intermediate type gets a positive profit, and the seller's lowest type gets a payoff exceeding $v(0) - c(0)$; by our results, the resulting expected payoffs are equilibrium payoffs in the bargaining game when frictions are small.²⁵

Yet this specific allocation, which requires the seller's high type not to trade, cannot be implemented in the bargaining game. To see this, note that the buyer will never accept an offer that gives him a strictly negative payoff, and therefore, because the buyer's expected payoff is zero, it must be that his expected payoff is also zero, conditional on any offer that is submitted with positive probability, after any history. By the martingale property of beliefs, there is a sequence of equilibrium offers along which the buyer's expected value, conditional on these offers, is non-decreasing, and therefore, at least as large as $(v_1 + v_2)/2 > c_3$. This sequence of offers must involve offers accepted with positive probability, for otherwise the seller's intermediate type would not be willing to follow it. By mimicking this sequence of offers, the seller's highest type guarantees a strictly positive profit, a contradiction.

²⁵Such an example is easy to find with a mathematical software: for instance, it occurs for the parameters $c_1 = 1, c_2 = 5970/2142, c_3 = 175/51$, and $v_1 = 134/65, v_2 = 2458/509, v_3 = 5$. The allocation is $x_1 = 1, x_2 = 1309475796/1359864155, x_3 = 0, p_1 = 926734382/271972831, p_2 = 898659860/271972831, p_3 = 0$.

References

- Akerlof, G. (1970). “The Market for ‘Lemons’: Quality Uncertainty and the Market Mechanism,” *Quarterly Journal of Economics*, **84**, 488–500.
- Ausubel, L. M. and R. J. Deneckere (1989). “A Direct Mechanism Characterization of Sequential Bargaining with One-Sided Incomplete Information,” *Journal of Economic Theory*, **48**, 18–46.
- Bester, H. and R. Strausz (2001). “Contracting with imperfect commitment and the revelation principle: the single agent case,” *Econometrica*, **69**, 1077–1098.
- Deneckere, R. and M.-Y. Liang (2006). “Bargaining with Interdependent Values,” *Econometrica*, **74**, 1309–1364.
- Forges, F. (1994). “Posterior Efficiency,” *Games and Economic Behavior*, **6**, 238–261.
- Forges, F. (1999). “Ex post individually rational trading mechanisms,” in: Alkan, A., C. Aliprantis et N. Yannelis (eds.), *Current trends in Economics*, Springer-Verlag, 157–175.
- Fudenberg, D., D. K. Levine and J. Tirole (1985). “Infinite-Horizon Models of Bargaining with One-Sided Incomplete Information,” in A. Roth (ed.), *Game Theoretic Models of Bargaining*, Cambridge University Press, 73–98.
- Fudenberg, D. and J. Tirole (1991). *Game Theory*. Cambridge, MA: MIT Press.
- Gresik, T. (1991a). “Ex ante efficient, ex post individually rational trade,” *Journal of Economic Theory*, **53**, 131–145.
- Gresik, T. (1991b). “Ex ante incentive efficient trading mechanisms without the private value restriction,” *Journal of Economic Theory*, **55**, 41–63.
- Hellwig, M. F. (2009). “A Maximum Principle for Control Problems with Monotonicity Constraints,” Preprint of the Max Planck Institute for Research on Collective Goods, Bonn, 2008/4.

- Matthews, S. and A. Postlewaite (1989). “Preplay communication in two-person sealed-bid double actions,” *Journal of Economic Theory*, **48**, 238–263.
- Myerson, R. B. (1981). “Optimal Auction Design,” *Mathematics of Operations Research*, **6**, 58–73.
- Myerson, R. B. (1985). “Analysis of Two Bargaining Games with Incomplete Information,” in A. Roth (ed.), *Game Theoretic Models of Bargaining*, Cambridge University Press, 115–147.
- Mylovanov, T. (2008). “Veto-Based Delegation,” *Journal of Economic Theory*, **138**, 297–307.
- Posner, R.A. (2002). “Economic Analysis of Contract Law After Three Decades: Success or Failure?” *Yale Law Journal*, **112**, 829–880.
- Riley, J. G. and R. Zeckhauser (1983). “Optimal Selling Strategies: When to Haggle, and When to Hold Firm,” *Quarterly Journal of Economics*, **76**, 267–287.
- Rothschild, M. and J. Stiglitz (1976). “Equilibrium in Competitive Insurance Markets: An Essay on the Economics of Imperfect Information,” *The Quarterly Journal of Economics*, **90**, 629–649.
- Rubinstein, A. (1982). “Perfect Equilibrium in a Bargaining Model,” *Econometrica*, **50**, 97–109.
- Samuelson, W. (1984). “Bargaining under Asymmetric Information,” *Econometrica*, **52**, 995–1005.
- Schelling, T. (1956). “An Essay On Bargaining,” *American Economic Review*, **46**, 281–306.
- Williamson, O. (1983). “Credible Commitments: Using Hostages to Support Exchange,” *American Economic Review*, **73**, 519–540.

Online Appendix: Omitted Proofs (Not for Publication)

Appendix A: Proof of Proposition 1 and Theorem 2.1

A.1. Proof of Proposition 1 (Remaining Details)

In the proof, Lemma 3 only covers the special case in which cost and value functions are step functions with two steps only. This appendix covers the general case in which no such assumption is made. The proof is in two steps. First, an induction on the number of steps is made to generalize Lemma 3 to an arbitrary number of steps. Second, a limiting argument is used to establish the result for arbitrary (not necessarily step) functions c and v .

Lemma 6 *If c and v are step functions, and (x, p) is an allocation that is implementable in the full commitment program, and such that, for all $t \in T$,*

$$B(t) = \int_t^1 (x(s)(v(s) - p(s))ds \geq 0,$$

then (x, p) is also implementable in the veto-incentive compatible program.

Proof. Since c and v are step functions, we may equivalently describe the environment as finite: there are N types, with cost and values

$$c_1 \leq c_2 \leq \dots \leq c_N, \text{ and } v_1 \leq v_2 \leq \dots \leq v_N.$$

To avoid some trivial but distracting complications, we shall assume that the inequalities involving costs are strict: $\forall i < n, c_i < c_{i+1}$. The probability of each type (*i.e.*, the length of each step) is denoted q_i .²⁶ An allocation, then, reduces to a pair of vectors $x = (x_1, \dots, x_N)$,

²⁶More precisely, the number of types N is the number of types $t_i \in T$ for which either c or v (or both) has a discontinuity. The length of the interval refers to the intervals defined by the corresponding partition of T .

$p = (p_1, \dots, p_N)$.

The hypothesis that $B(t) \geq 0$ for all $t \in T$ implies that, for all $J = 1, \dots, N$,

$$\sum_{i=J}^N x_i q_i v_i \geq \sum_{i=J}^N x_i q_i p_i. \quad (13)$$

We shall show that any incentive-compatible, individually rational allocation satisfying this condition can be implemented in the veto-incentive compatible program, using N prices. The proof is by induction on the number of types (uniformly over all cost, values and probabilities).

Note that this is true for $N = 1$. In that case, the buyer's individual rationality constraint implies $p_1 \leq v_1$ (which trivially implies our hypothesis), while the seller's individual rationality constraint implies $p_1 \geq c_1$. Note then that any such allocation (x_1, p_1) with $p_1 \in [c_1, v_1]$ satisfies the veto-incentive compatibility constraint: conditional on p_1 , the buyer assigns probability one to the (unique) type 1, and since $v_1 \geq p_1$, his payoff conditional on this event is positive.

Assume then that, whenever there are N types, and for any collection of costs, values and probabilities $\{(c_1, v_1, q_1), \dots, (c_N, v_N, q_N)\}$, any incentive compatible, individually rational allocation $\{(x_1, p_1), \dots, (x_N, p_N)\}$ that satisfies (13) can be implemented in the veto-incentive compatible program with N (not necessarily distinct) prices. Consider the case of $N + 1$ types, with cost, values and probabilities $\{c_i, v_i, q_i\}_{i=1}^{N+1}$. Fix some incentive compatible, individually rational allocation

$$\{(x_1, p_1), \dots, (x_{N+1}, p_{N+1})\},$$

satisfying (13). The argument is divided into three steps.

Step 1. Note that, by (13) with $J = N + 1$, $p_{N+1} \leq v_{N+1}$. Also, incentive compatibility implies that $p_N \leq p_{N+1}$.²⁷ It follows that there exists $z \in [0, x_{N+1}/x_N]$ such that

$$zx_N p_N + (x_{N+1} - zx_N) v_{N+1} = x_{N+1} p_{N+1}. \quad (14)$$

To see this, note that, for $z = 0$, the left-hand side reduces to $x_{N+1} v_{N+1}$, which is at least as large as the right-hand side, while for $z = x_{N+1}/x_N$, the left-hand side reduces to $x_{N+1} p_N$, which is at most as large as the right-hand side. Fix some z satisfying (28).

Step 2. Consider the game in which there are N types, with costs and values $\{\hat{c}_i, \hat{v}_i, \hat{q}_i\}_{i=1}^N$, defined as follows. Costs are unchanged: $\hat{c}_i := c_i$, all $i = 1, \dots, N$. Values are given by

$$\hat{v}_i := v_i \text{ for } i < N, \text{ and } \hat{v}_N := \frac{q_N v_N + q_{N+1} z v_{N+1}}{q_N + q_{N+1} z},$$

(note that $\hat{v}_N \geq v_N > \hat{c}_N$), while probabilities are

$$\hat{q}_i := \frac{q_i}{\sum_{j \leq N} q_j + q_{N+1} z} \text{ for } i < N, \text{ and } \hat{q}_N := \frac{q_N + q_{N+1} z}{\sum_{i \leq N} q_i + q_{N+1} z}.$$

We claim that the allocation $\{(x_i, p_i)\}_{i=1}^N$ (derived from $\{(x_i, p_i)\}_{i=1}^{N+1}$) is implementable, in this new environment, in the veto-incentive compatible program.

First, because costs are the same in this environment as in the original environment, individual rationality and incentive compatibility for all seller's types is implied by the fact that these were satisfied by the allocation $\{(x_i, p_i)\}_{i=1}^{N+1}$ in the original environment.

²⁷The argument is standard: considering the two incentive compatibility conditions involving types N and $N + 1$ only, it follows that $x_N \geq x_{N+1}$ and $p_N \leq p_{N+1}$.

Therefore, to show that this allocation is implementable in the veto-incentive compatible program, given the induction hypothesis, it suffices to show that, for all $J \leq N$,

$$\sum_{i=J}^N x_i \hat{q}_i \hat{v}_i \geq \sum_{i=J}^N x_i \hat{q}_i p_i.$$

(Note that individual rationality for the buyer is the special case $J = 1$.) Simplifying,

$$\sum_{i=J}^N x_i \hat{q}_i (\hat{v}_i - p_i) = \frac{1}{\sum_{i \leq N} q_i + q_{N+1} z} \left[\sum_{i=J}^{N-1} x_i q_i (v_i - p_i) + q_N x_N (v_N - p_N) + q_{N+1} x_N z (v_{N+1} - p_N) \right].$$

Adding and subtracting $(x_{N+1} - x_N z) v_{N+1}$ to the expression inside the square brackets yield

$$\sum_{i=J}^N x_i \hat{q}_i (\hat{v}_i - p_i) = \frac{1}{\sum_{i \leq N} q_i + q_{N+1} z} \left[\begin{array}{l} \sum_{i=J}^{N-1} x_i q_i (v_i - p_i) + q_N x_N (v_N - p_N) + \\ q_{N+1} (x_{N+1} v_{N+1} - x_N z p_N - (x_{N+1} - x_N z) v_{N+1}) \end{array} \right].$$

Using the definition of z , we finally obtain

$$\sum_{i=J}^N x_i \hat{q}_i (\hat{v}_i - p_i) = \frac{1}{\sum_{i \leq N} q_i + q_{N+1} z} \left[\sum_{i=J}^{N+1} x_i q_i (v_i - p_i) \right] \geq 0,$$

where the last inequality uses that, by assumption, the allocation satisfies (13).

Therefore, by the induction hypothesis, the allocation $\{(x_i, p_i)\}_{i=1}^N$ is implementable in the veto-incentive compatible program, in this new environment, with N prices. Let $\{\hat{r}_1, \dots, \hat{r}_N\}$ be the prices that implement this allocation in the veto-incentive compatible program, and $\{\hat{x}_1(r), \dots, \hat{x}_N(r)\}_{r \in \{\hat{r}_1, \dots, \hat{r}_N\}}$ be the probabilities assigned to these prices.

Step 3. We now construct a set of prices $\{r_1, \dots, r_{N+1}\}$ and probabilities $\{x_1(r), \dots, x_{N+1}(r)\}$, $r \in \{r_1, \dots, r_{N+1}\}$, that implement $\{(x_1, p_1), \dots, (x_{N+1}, p_{N+1})\}$ in the veto-incentive compatible program, in the original environment.

The prices are given by

$$\{r_1, \dots, r_{N+1}\} = \{\hat{r}_1, \dots, \hat{r}_N\} \cup \{v_{N+1}\}.$$

The probabilities are given by, for $i < N + 1$,

$$x_i(r) = \hat{x}_i(r), \forall r \in \{\hat{r}_1, \dots, \hat{r}_N\}, \text{ and } x_i(v_{N+1}) = 0,$$

and

$$x_{N+1}(r) = z\hat{x}_N(r) \forall r \in \{\hat{r}_1, \dots, \hat{r}_N\}, \text{ and } x_{N+1}(v_{N+1}) = x_{N+1} - zx_N.$$

It is immediate to see that, conditional on any given $r \in \{\hat{r}_1, \dots, \hat{r}_N\}$, the conditional value is the same as in the modified environment, so that the buyer's veto-incentive compatibility constraint holds. This is also true if $r = v_{N+1}$, because the only seller's type trading at this price is type $N + 1$. Furthermore, by construction, buyer i trades with probability x_i and receives an average price p_i . This completes the proof. ■

Finally, we can show sufficiency for arbitrary cost and value functions.

Lemma 7 *If (x, p) is an individually rational and incentive compatible allocation such that, for all $t \in T$,*

$$B(t) = \int_t^1 x(s)[v(s) - p(s)]ds \geq 0,$$

then (x, p) is implementable in the veto-incentive compatible program.

Proof. Fix an allocation (x, p) that satisfies the assumptions of the lemma. Consider a sequence of partitions $\mathcal{P}^n = \{t_1^n, \dots, t_n^n\}$, with $t_1^n = 0, t_n^n = 1, \max_i |t_i^n - t_{i+1}^n| < K/n$ for some constant K independent of n , and such that $D \subseteq \mathcal{P}^n$, where D is the set of discontinuities of either v or c (without loss of generality, assume that n is large enough to include this finite set).

We now define a sequence of functions $c^n, v^n : T \rightarrow \mathbb{R}_+$ as follows: for all $t < 1$, set $c^n(t) := c(t_j^n)$ for $t \in [t_j^n, t_{j+1}^n)$, $c^n(1) := c(t_{n-1}^n)$, as well as, for all $t < 1$, $v^n(t) := v(t_{j+1}^n)$ for $t \in [t_j^n, t_{j+1}^n)$, $v^n(1) := v(t_n^n)$.

Further, define the sequence of allocations x^n, p^n as follows: for all $t \in T$, set $x^n(t) := x(t_j^n)$, and $p^n(t) := p(t_j^n)$ for $t \in [t_j^n, t_{j+1}^n)$, $j < n - 1$ ($t \in [t_j^n, t_{j+1}^n]$ if $j = n$).²⁸

Note that the allocation (x^n, p^n) is incentive compatible and individually rational for the seller given the functions (c^n, v^n) (because the choices of the types in the set \mathcal{P}^n are incentive compatible and individually rational given the original allocation (x, p) .) Define

$$B_j^n := \int_{t_j^n}^1 x^n(s)[v^n(s) - p^n(s)]ds.$$

Because $x(t_{j+1}^n) \leq x(t) \leq x(t_j^n)$ and $p(t_{j+1}^n) \leq p(t) \leq p(t_j^n)$ (by incentive compatibility) for $t \in [t_j^n, t_{j+1}^n)$, $j < n - 1$, we can pick these sequences such that, because $B(t_j^n) \geq 0$ (the lemma's hypothesis), it is also the case that also $B_j^n \geq 0$ for all j (clearly, $B_n^n = 0$). Therefore, the allocation (x^n, p^n) is individually rational for the buyer given (c^n, v^n) and further, given Lemma 7, this allocation is veto-incentive compatible in the game with cost and value functions (c^n, v^n) . Let μ^n denote the corresponding mechanism. The mechanism μ^n defines a function x^n specifying the probability of trade given some message t , and a joint distribution $\tilde{\mu}^n$ on $T \times \mathbb{R}_+$ in case that there is a trade for each type.²⁹ Let $\hat{\mu}^n$ denote the product distribution whose marginals coincide with those of $\tilde{\mu}^n$. Note that incentive compatibility and veto-incentive compatibility are restrictions on the marginal distributions only, so that any mechanism inducing the pair x^n and $\hat{\mu}^n$ also implements (x^n, p^n) . Note that, by construction, (x^n, p^n) converge (pointwise) to (x, p) , and similarly, (c^n, v^n) converge pointwise to (c, v) . Also, since we can replace the set of prices \mathbb{R}_+ by the compact interval $[0, v(1)]$ (because $v(1)$ is an upper bound on the price that can be in

²⁸Note that the functions v^n, c^n as well as the allocations x^n, p^n are right-continuous.

²⁹More precisely, $x = \mu(\cdot)[1, \mathbb{R}_+]$, as defined in Section 2, and the distribution $\tilde{\mu}$ is the joint distribution $\nu((1, \cdot), \cdot)$, where ν is the conditional distribution defined in Section 2 as well.

the support of any mechanism that is veto-incentive compatible), a subsequence of the sequence $\{\hat{\mu}^n\}$ (without loss of generality the sequence itself) must converge weakly to some distribution $\hat{\mu}$. It follows from Theorem 3.2 of Billingsley (1968) that $\hat{\mu}$ must itself be a product distribution, and that the marginals of $\hat{\mu}^n$ converge weakly to the marginals of $\hat{\mu}$. Therefore, for all prices p , the marginal distribution $\hat{\mu}^n(\cdot | p)$ converges weakly to $\hat{\mu}(\cdot | p)$, and so it follows that, for all p ,

$$\int_T \hat{\mu}(t | p)(v(t) - p)dt \geq 0,$$

which is precisely the requirement of veto-incentive compatibility. Therefore, along with x , $\hat{\mu}$ defines a veto-incentive compatible mechanism. (Incentive compatibility and individual rationality are satisfied by hypothesis, given the limiting allocation (x, p)). ■

Note that Lemma 2 and 7 immediately imply Proposition 1.

A.2. Proof of Theorem 2.1

Here, we prove the three claims stated in Section 4.1.2. Assume that $v > c$. (Simple changes have to be made otherwise.) Given (x, p) , let $\bar{t} := \sup\{t \in T : x(t) > 0\}$.³⁰

Clearly, $(0, 0)$ is an extreme point of this set, and because it is achieved by the allocation $(x, p) = (0, 0)$, the claims are trivially valid for this point. We further divide this boundary into $\Pi_-^V := \{(\pi^S, \pi^B) \in \mathbb{R}^2 : \pi^B = \max_{(\pi_1, \pi_2) \in \Pi^V} \pi_2 \text{ s.t. } \pi_1 \leq \pi^S\}$ and $\Pi_+^V := \{(\pi^S, \pi^B) \in \mathbb{R}^2 : \pi^B = \max_{(\pi_1, \pi_2) \in \Pi^V} \pi_2 \text{ s.t. } \pi_1 \geq \pi^S\}$. As will be clear, Π_+^V intersects the axis $\{(\pi^S, 0) : \pi^S \in \mathbb{R}\}$, so that $\Pi^V = \text{co}\{(0, 0)\} \cup \Pi_+^V \cup \Pi_-^V$, where, given any set A , $\text{co } A$ denotes the convex hull of A .

Let us establish three claims for $\Pi_+^V \cup \Pi_-^V$ at once. If (x, p) achieves $\pi \in \Pi_+^V \cup \Pi_-^V$, then

1. $\lim_{s \downarrow t} \pi^S(s | t) = \pi^S(t)$ for all t . Suppose that this is not the case. First, consider the case in which the payoff is in Π_+^V . Take the supremum over \hat{t} such that $\pi^S(\hat{t}) > \lim_{s \downarrow \hat{t}} \pi^S(s | \hat{t})$.

Clearly, \hat{t} is a point of discontinuity of $c(t)$ and $x(t)$. Consider then the following alternative

³⁰Not to be confused with \bar{t} as defined in (9).

allocation (x', p') , defined by

$$\begin{aligned} x'(t) &= x(t) + \varepsilon \text{ if } t \in [\hat{t}, \hat{t} + \varepsilon), \quad x'(t) = x(t) && \text{otherwise;} \\ \bar{p}'(t) &= \bar{p}(t) + \varepsilon c(t + \varepsilon) \text{ if } t \in [\hat{t}, \hat{t} + \varepsilon), \quad \bar{p}'(t) = \bar{p}(t) && \text{otherwise.} \end{aligned}$$

It is straightforward to see that, for small enough $\varepsilon > 0$, this is incentive-compatible, satisfies $B(t) \geq 0$ for all t and strictly improves the buyer's payoff, while weakly improving the seller's payoff. Consider next the case in which the payoff of (x, p) belongs to Π_-^V . Take the supremum over \hat{t} such that $\pi(\hat{t}) > \lim_{s \downarrow \hat{t}} \pi(s | \hat{t})$. Clearly, \hat{t} is a point of discontinuity of $c(t)$. Thus consider the alternative allocation (x', p') , defined by

$$\begin{aligned} x'(t) &= x(t) && \text{for all } t \in [0, 1], \\ \bar{p}'(t) &= \bar{p}(t) - \varepsilon \text{ if } t \in [0, \hat{t}); \quad \bar{p}'(t) = \bar{p}(t) && \text{otherwise.} \end{aligned}$$

It is straightforward to check that for small $\varepsilon > 0$ this allocation is implementable. Moreover, it decreases the seller's payoff and increases the buyer's payoff, which contradicts the assumption that the payoff is in Π_-^V .

2. $\pi^S(\bar{t}_-) = 0$, where $\bar{t} := \sup\{t \leq 1 : x(t) > 0\}$ is the highest seller's type that trades with positive probability. Suppose towards a contradiction that this is not the case. Consider first the case in which the payoff is in Π_-^V . Modify the allocation by decreasing $p(t)$ (for all t such that $x(t) > 0$) by some small $\varepsilon > 0$, contradicting that $\pi \in \Pi_-^V$. Suppose next that $\pi \in \Pi_+^V$. Fix some small $\eta > 0$ and let $t^* := \sup\{t : x(t) - x(\bar{t}_-) > \eta\}$. Since the allocation is right-continuous, $x(t^*) \leq x(\bar{t}_-) + \eta$. Thus, define \hat{p} such that $x(t^*)(p(t^*) - c(t^*)) = [x(\bar{t}_-) + \eta](\hat{p} - c(t^*))$, and consider the alternative allocation

$$\begin{aligned} \hat{x}(t) &= x(\bar{t}) + \eta \text{ if } t \in [t^*, \bar{t}), \quad \hat{x}(t) = x(t) && \text{otherwise;} \\ \hat{p}(t) &= \hat{p} \text{ if } t \in [t^*, \bar{t}), \quad \hat{p}(t) = p(t) && \text{otherwise.} \end{aligned}$$

The payoff of each seller's type weakly decreases in this alternative allocation, while the

buyer's payoff strictly increases (since c is piecewise continuous and $v(t) > c(t)$ the allocation remains implementable for small η). If the seller's payoff remains constant, we are done, so assume it decreases by $\alpha > 0$. There exists $\varepsilon > 0$ such that $\int_0^{\bar{t}} \varepsilon dt = \alpha$. Thus, increase all prices by ε , so that the seller's overall payoff does not change.³¹ This is incentive compatible and increases the buyer's payoff. Thus, since the surplus increase goes to the buyer, it is enough to show that $B(t) \geq 0$, all t . Note that the buyer's *ex ante* payoff changes by

$$\begin{aligned} \Delta B(0) &= \int_0^{\bar{t}} (\Delta x(t) (v(t) - c(t))) dt - \int_0^{\bar{t}} (\Delta \bar{p}(t) - \Delta x(t) c(t)) dt \\ &= \int_0^{\bar{t}} (\Delta x(t) (v(t) - c(t))) dt > 0, \end{aligned}$$

where $\Delta x(t) := x'(t) - x(\bar{t})$ and $\Delta \bar{p}(t) := \bar{p}'(t) - \bar{p}(\bar{t})$. Furthermore,

$$\Delta x(t) (v(t) - c(t)) + (\Delta \bar{p}(t) - \Delta x(t) c(t)) < 0,$$

if and only if $t < t^{**} \in [t^*, \bar{t})$. Thus $\Delta B(t) \geq 0$ for all t , which completes the argument.

3. $x(0) = 1$. Suppose towards a contradiction that $x(0) < 1$. Since the cost function is piecewise right-continuous and piecewise C^1 we take an interval $[0, \eta]$ such that (c, v) are differentiable on that interval. Fix $n' \in \mathbb{N}$ such that $1/n' < \eta$, and consider the following alternative allocation (x_n, \bar{p}_n) defined as

$$\begin{aligned} x_n(t) &:= x(t) + (1 - x(0)) \text{ if } t \in [0, \frac{1}{n}), \quad x_n(t) = x(t) \quad \text{otherwise;} \\ \bar{p}_n(t) &:= \bar{p}(t) + c(\frac{1}{n}) (1 - x(0)) \text{ if } t \in [0, \eta), \quad \bar{p}_n(t) = \bar{p}(t) \quad \text{otherwise.} \end{aligned}$$

Notice that there exists $m > n'$ such that this allocation is implementable (and is also a Pareto improvement for all $n > m$). If $\pi \in \Pi_+^V$, this is a contradiction. If instead $\pi \in \Pi_-^V$ such that $\pi^S > 0$, let $k > 0$ be the supremum of the subgradients of the payoff set at π . Now

³¹Notice that the sellers with types $[t^*, \bar{t})$ are made worse off, while sellers with types $[0, t^*)$ are made better off. Hence, the allocation $(0, 0)$ is still optimal for types in $[\bar{t}, 1)$ when $\bar{t} < 1$.

notice that for each n the payoff of the buyer increases by $(1 - x(0)) \int_0^{\frac{1}{n}} (v(s) - c(1/n)) ds$, while the payoff of the seller increases by $(1 - x(0)) \int_0^{\frac{1}{n}} (c(s) - c(1/n)) ds$. Thus the ratio of the increase in the payoff of the buyer and the seller is arbitrarily large as $n \rightarrow \infty$, and for n large enough, both payoffs can be increased at a rate greater than k , a contradiction. If $\pi \in \Pi_-^V$ and $\pi^s = 0$, then either (i) c is constant in a neighborhood of 0, or (ii) $c(t) > c(0)$ for all $t > 0$. If (i) holds, then one can readily see that for some small n the alternative allocation above increases the buyer's payoff while keeping the seller's payoff constant. If (ii) holds, then since c is right-continuous we have $\pi^B = 0$ and the claim is trivially true.

Appendix B: Proof of Lemma 5 (and finite horizon)

As mentioned, we restrict ourselves to the case of extreme points that lie on the Pareto-frontier here. Considering points on the “north-west” and “south-west” of the relevant payoff set require relatively straightforward modifications.

Lemma 8 *Every extreme point (π^S, π^B) of the payoff set that can be achieved by veto-incentive compatible allocations $(x, p) \in \Pi_+^V$ for which $\pi^S(0) > v(0) - c(0)$ can be approached by a regular allocation.*

Proof. Consider an allocation (x, p) satisfying the assumptions of the lemma. This allocation maximizes the weighted sum of the buyer and the seller payoff. For future reference, let $\beta \in (0, 1)$ be the seller's weight. Taking a sufficiently close allocation if necessary, assume that $\pi^S(0) \geq v(0) - c(0)$ (implicitly we assume that $v(0) < v(1_-)$).³²

Define $\hat{t} := \sup\{t : x(t) > 0\}$. It is straightforward to construct an allocation (x', p') such that: a) $\hat{t} := \sup\{t : x'(t) > 0\}$; b) $x'(t_-) > 0$; c) $p' \ll v$. Since the convex combination of feasible allocations is also a feasible allocation, take $\lambda \in (0, 1)$ and define $(x_\lambda, p_\lambda) := \lambda(x, p) + (1 - \lambda)(x', p')$

³²Otherwise the equilibrium outcome of the bargaining game is unique and involves the seller selling the good at $v(0)$ in the first period with probability 1.

satisfying $\|(x_\lambda, p_\lambda) - (x, p)\| < \frac{\varepsilon}{2}$ and $\pi_\lambda^S(0) > v(0) - c(0)$. Notice that for the allocation (x_λ, p_λ) we have $B_\lambda(0) > 0$ for all $t < \hat{t}$. Furthermore, notice that since (x_λ, p_λ) and (c, v) are left-continuous the assumptions a) and b) imply that there exists $t_2 < \hat{t}$ such that $p_\lambda(s) < v(t_2)$ for all $t \in (t_2, \hat{t})$. Therefore:

$$B_\lambda(t_2) = \int_{t_2}^{\hat{t}} x_\lambda(s) (v(s) - p_\lambda(s)) ds =: \vartheta > 0.$$

Next, we approach the allocation (x_λ, p_λ) with a step allocation.

- Step 1: For every $n \in \mathbb{N}$ we consider a mesh of $[0, \hat{t})$, $\{\mathcal{I}_j^n\}_{j=1}^{M_n} := \{[t_{1,1}^n, t_{2,1}^n), \dots, [t_{1,M_n}^n, t_{2,M_n}^n)\}$

such that

i) $\sum_j \max \left| \sup_{t \in \mathcal{I}_j^n} x_n(t) - \inf_{t' \in \mathcal{I}_j^n} x_n(t') \right| < \left(\frac{1}{n}\right)$;

ii) $x_n(t) = x_n(t')$ for all $t \in \mathcal{I}_j^n$ and $x_n(t_{2,j-}^n) = x_\lambda(t_{2,j-}^n)$ for every $t_{2,j}^n$;

iii) $p_n(t) = p_n(t')$ for all $t \in \mathcal{I}_j^n$; $p_n(t_{2,M_n-}^n) = p(t_{2,M_n-}^n)$ and for all $j < M_n$ we define $p_n(t_{2,j-}^n)$ by

$$p_n(t_{2,j-}^n) (x_n(t_{2,j-}^n) - c(t_{2,j-}^n)) = p_n(t_{2,j+1-}^n) (x_n(t_{2,j+1-}^n) - c(t_{2,j-}^n));$$

iv) All discontinuity points of c belong to the boundaries of the partition.

Notice that for every t we have

$$\bar{p}_n(t) = x_n(t)c(t) + \int_t^1 x_n(s)dc(s).$$

Notice that by construction $x_n(t) \rightarrow x(t)$ uniformly. Furthermore,

$$\begin{aligned} & |\bar{p}_n(t) - \bar{p}(t)| \\ & \leq |x_n(t)c(t) - x(t)c(t)| + \int_t^1 |x_n(s) - x(s)| dc(s). \end{aligned}$$

Hence, using iv) we conclude that $\bar{p}_n(t) \rightarrow \bar{p}(t)$ uniformly. Furthermore, there exists n_1 such that $n > n_1$ implies $B_n(t_1) \geq \frac{\vartheta}{2}$. Hence, the uniform convergence of \bar{p}_n and $x_n(t)$ guarantee that there exists $n_2 > n_1$ such that $\|(x_n, p_n) - (x_\lambda, p_\lambda)\| < \frac{\varepsilon}{2}$ and $B_n(t) > 0$ for all $t < \hat{t}$.

Step 2: Notice that the allocation (x_n, p_n) is a step function allocation and hence there are a finite partition of the types $\{[t_{1,1}^n, t_{2,1}^n), \dots, [t_{1,M_n}^n, t_{2,M_n}^n)\}$ such that all types $t \in [t_{1,j}^n, t_{2,j}^n)$ trade with the same probability. Hence, consider a fictitious game with finite types in which all types $t \in [t_{1,j}^n, t_{2,j}^n)$ have the same cost $c(t_{2,j}^n)$, the same value $\left(\frac{\int_{[t_{1,j}^n, t_{2,j}^n)} v(s) ds}{t_{2,j}^n - t_{1,j}^n}\right)$ and trade with the same probability. Furthermore, if $t_{2,j}^n < 1$ attribute the cost $c(1)$ and the value $\left(\frac{\int_{[t_{2,j}^n, 1)} v(s) ds}{1 - t_{2,j}^n}\right)$ to all types $t \in [t_{2,j}^n, 1)$. In this finite game, consider the allocation that maximizes the weighted sum of the buyer's payoff and the seller's payoff (weight β to the seller) such that all types $t \in [t_{1,j}^n, t_{2,j}^n)$, $j \leq M_n$ and all types $t \in [t_{2,j}^n, 1)$ trade with the same probability. This is a finite dimensional compact problem. Hence, it admits a solution. Since (x_n, p_n) is feasible, the solution leads to a weakly higher value for the objective function. It is straightforward to show that any solution to this problem is a regular allocation and, from Theorem 2.1, we know that all downward constraints are binding and the last type of the seller who trades with positive probability obtains zero payoff. This completes the proof.

■

Finite Horizon

We show below how to implement regular allocations (see Definition 1) when the horizon N ($N \geq 2$) is finite and the players do not discount the future.

- All types make non-serious offers (*e.g.*, $p_n = v(1) + 1$) in every period $n < N - 1$.
- Types $t \in [0, t_1]$ offer p_1 at period $N - 1$ which is accepted with probability 1.
- For $j = 1, \dots, K - 3$, sellers with types $t \in [t_j, t_{j+1}]$ make a non-serious offer at period $N - 1$ and offer p_{j+1} at period N . The buyer accepts this offer with probability x_{j+1} . Notice that it is rational for the buyer to randomize since the buyer breaks even by accepting any such offer (because $B(t_1) = \dots = B(t_{K-2}) = 0$).
- Types $t \in [t_{K-2}, t_K]$ offer $v_{t_{K-2}}^{t_K}$ at period $N - 1$. The buyer accepts this offer with probability $x_{K-1}\beta$ (recall that β is defined in (11)). If this offer is rejected, all types $t \in [t_{K-2}, t_{K-1}]$ offer $v_{t_{K-2}}^{t_{K-1}}$ at period N , while all types $t \in [t_{K-1}, t_K]$ offer $v_{t_{K-1}}^{t_K}$ at period N . The offer $v_{t_{K-2}}^{t_{K-1}}$ is accepted with probability ς_{K-1} , which is defined by $x_{K-1} = x_{K-1}\beta + (1 - x_{K-1}\beta)\varsigma_{K-1}$, while the offer $v_{t_{K-1}}^{t_K}$ is accepted with probability ς_K , which is defined by $x_K = x_{K-1}\beta + (1 - x_{K-1}\beta)\varsigma_K$. Again, it is rational for the buyer to randomize since he breaks even by accepting any of the offers above.

It is easy to see that the buyer has no profitable deviation. For the seller, we assume that the buyer puts probability 1 on the seller being type $t = 0$ (and never revises his belief) after an off-path offer. Therefore, the best deviation by a seller would be to imitate all types $t \in [0, t_1]$ and offer p_1 at period $N - 1$. Thus since regular allocations are incentive compatible (see (3) in Definition 1) we conclude that no type has a profitable deviation.

Appendix C: Relaxing the Co-Monotonicity of v and c

We have maintained throughout the assumption that both the seller's cost, and the buyer's value are non-decreasing. Of course, there is no loss of generality in assuming that one of these functions is non-decreasing. So let us assume that types are ordered so that only the cost function is non-decreasing, and maintain all other assumptions (besides monotonicity). In particular, gains from trade are bounded away from zero for all t , and, to avoid trivialities, the seller's highest cost exceeds the buyer's average value. Does there exist a similarly tractable characterization of the veto-incentive compatible program when the value function is not necessarily increasing? In that case, it is easy to see that $B(t) \geq 0$ for all t is no longer a necessary condition, although it remains a sufficient condition for implementability. This suggests that non-negative correlation singles out the collection of intervals $\{[t, 1] : t < 1\}$ as the relevant one for the domains of the integral constraints $B(t)$. We view it as an important next step to identify what the "right" collection of intervals is, if any, over which the expected buyer's payoff must be positive, when values are not positively correlated, before turning to more general environments with limited commitment and private information.

In the absence of such a characterization, we might still ask the question: under which conditions is the *ex ante* efficient (*i.e.*, surplus-maximizing) allocation of the commitment program also implementable in the veto-incentive program, or even in the bargaining game as frictions disappear? The answer to this question is surprisingly simple. Recall that the *ex ante* efficient mechanism under full commitment takes a very simple form, with (at most) two thresholds t_1 and t_2 , with $0 < t_1 \leq t_2 \leq 1$. If $t_1 = t_2$, it is trivial to implement the allocation in the game, and, *a fortiori*, in the veto-incentive compatible program, so let us assume that $t_2 > t_1$. We have the following necessary and sufficient condition, which generalizes Proposition 1, at the cost of being stated in terms of endogenous variables (t_1, t_2) .

Proposition 4 *If $t_2 > t_1$, the ex ante efficient allocation of the commitment program is imple-*

mentable in the bargaining game as $\delta \rightarrow 1$ if and only if

$$c(t_2) \leq \frac{1}{t_2 - t_1} \int_{t_1}^{t_2} v(t) dt.$$

Proof. Sufficiency follows closely the construction in 4.2.3 and is omitted. We focus here on necessity.

This proof makes clear that the condition is equally necessary for veto-incentive compatibility. This, this condition is also necessary and sufficient for implementability in the veto-incentive compatible program. Recall that, in the *ex ante* efficient allocation, the seller's expected transfers $\bar{p}(t)$ are given by

$$\bar{p}(t) = \begin{cases} (1-x)c(t_1) + xc(t_2) & t \in [0, t_1], \\ xc(t_2) & t \in [t_1, t_2], \\ 0 & t > t_2. \end{cases}$$

Define the set \hat{T} as

$$\hat{T} := \{t \in [0, t_2] : v(t') \leq v(t) \text{ for every } t' \in [0, t_2]\}.$$

Throughout we assume that the set \hat{T} is nonempty (this is not guaranteed by our assumptions, and minor adjustments are necessary otherwise). To ease notation, we let \hat{v} denote the value of the function v over the set \hat{T} .

Suppose that $c(t_2) > v_{t_1}^{t_2}$. We want to show that it is impossible to construct a collection of distributions $(\mu(\cdot | t))_{t \in [0, t_2]}$ over the interval $[0, \hat{v}]$ which satisfy the following three conditions:

i) for every $t \in [0, t_2]$,

$$\int_0^{\hat{v}} d\mu(p | t) = x(t), \tag{15}$$

ii) for every $t \in [0, t_2]$,

$$\int_0^{\hat{v}} pd\mu(p | t) = \bar{p}(t), \tag{16}$$

iii) for all $p \in [0, \hat{v}]$,

$$\int_0^{t_2} (v(t) - p) d\mu(p | t) = 0.$$

(Recall that under the *ex ante* efficient mechanism the buyer's expected payoff is equal to zero).

We approximate the function v by a sequence of step functions v^n , $n \in \mathbb{N}$. In particular, each v^n satisfies

i) for every $t \in [0, t_2]$,

$$v(t) \leq v^n(t) \leq \hat{v},$$

ii) for every $t \in [0, 1]$,

$$0 \leq v^n(t) - v(t) \leq \frac{1}{n},$$

iii) if t and t' belong to the same step of v^n , then $x(t) = x(t')$.

Finally, for each $n \in \mathbb{N}$, we let $I^n \subset [0, t_2]$ denote the union of the intervals over which the function v^n takes the value \hat{v} .

Fix $n \in \mathbb{N}$. For each $p < \hat{v}$ we have

$$\int_0^{t_2} (v^n(t) - p) d\mu(p | t) = \varepsilon^n(p),$$

for some $\varepsilon^n(p) \geq 0$. After dividing both sides by $\hat{v} - p$ and rearranging terms, we have

$$\int_{t \in I^n} d\mu(p | t) + \int_{t \in [0, t_2] \setminus I^n} \left(1 - \frac{\hat{v} - v^n(t)}{\hat{v} - p}\right) d\mu(p | t) = \frac{\varepsilon^n(p)}{\hat{v} - p} \geq 0.$$

We integrate the two sides of the equality over p , and get

$$z^n := \int_{t \in I^n} \int_0^{\hat{v}} d\mu(p | t) dt + \int_{t \in [0, t_2] \setminus I^n} \int_0^{\hat{v}} \left(1 - \frac{\hat{v} - v^n(t)}{\hat{v} - p}\right) d\mu(p | t) dt \geq 0.$$

For each $t \in [0, t_2] \setminus I^n$, let $\bar{\mu}(\cdot | t)$ denote the distribution that assigns probability $x(t)$ to the offer $\bar{p}(t)/x(t)$ (with probability $1 - x(t)$ no offer is made). Notice that the function $\frac{1}{p - \hat{v}}$ is

concave in p . This, together with conditions (15) and (16), implies that, for each $n \in \mathbb{N}$,

$$\bar{z}^n := \int_{t \in I^n} \int_0^{\hat{v}} d\bar{\mu}(p | t) dt + \int_{t \in [0,1] \setminus I^n} \int_0^{\hat{v}} \left(1 - \frac{\hat{v} - v^n(t)}{\hat{v} - p}\right) d\bar{\mu}(p | t) dt \geq tz^n \geq 0. \quad (17)$$

We take the limit of \bar{z}^n as n goes to infinity, so that

$$\begin{aligned} \bar{z} &:= \lim_{n \rightarrow \infty} \bar{z}^n = t_1 + (t_2 - t_1)x - \frac{\int_0^{t_1} (\hat{v} - v(t)) dt}{\hat{v} - (1-x)c(t_1) - xc(t_2)} - x \frac{\int_{t_1}^{t_2} (\hat{v} - v(t)) dt}{\hat{v} - c(t_2)} = \\ &= \frac{t_1(v_0^{t_1} - (1-x)c(t_1) - xc(t_2))}{\hat{v} - (1-x)c(t_1) - xc(t_2)} - \frac{x(t_2 - t_1)(c(t_2) - v_{t_1}^{t_2})}{\hat{v} - c(t_2)} < \frac{t_1(v_0^{t_1} - (1-x)c(t_1) - xc(t_2)) - x(t_2 - t_1)(c(t_2) - v_{t_1}^{t_2})}{\hat{v} - (1-x)c(t_1) - xc(t_2)} = 0, \end{aligned}$$

where the inequality follows from the fact that $c(t_2) > v_{t_1}^{t_2}$, and the last equality follows from the definition of x in equation (6). However, \bar{z} being strictly negative contradicts the fact that it is the limit of a sequence of nonnegative numbers (see condition (17)). ■

Appendix D: A Sufficient Condition for the Efficient Mechanism to be Implemented in the Bargaining Game

Recall that $Y : [0, 1] \rightarrow \mathbb{R}$ is defined as

$$Y(t) := \int_0^t (v(s) - c(t)) ds = \int_0^t (v(s) - c(s) - sc'(s)) ds.$$

Our assumptions imply that, as mentioned, $Y(0) = 0$, $Y'(0) > 0$ (if $v > c$) and $Y(1) < 0$. Let \underline{t} denote the smallest local maximizer of the function Y . Also, let \bar{t} denote the smallest strictly positive root of Y . For any t let $\mu(t)$ denote the mechanism under which the types below t trade with probability one at the price $c(t)$ and the types above t do not trade. Notice that if $Y(t) \geq 0$, then the mechanism $\mu(t)$ is incentive compatible and individually rational.

Consider the efficient mechanism under full commitment. We know that there exist $0 < t_1 \leq t_2 \leq 1$ such that the seller's types in $[0, t_1)$ trade with probability 1, while the types in $[t_1, t_2]$

trade with probability $x(t_1, t_2) \in [0, 1]$ (all other types of the seller do not trade). Recall that the buyer's individual rationality constraint holds with equality. Thus, we have

$$0 = \int_0^{t_1} (v(s) - c(t_1)) ds + x \left(t_1 c(t_1) + \int_{t_1}^{t_2} v(s) ds - t_2 c(t_2) \right) = Y(t_1) + x \int_{t_1}^{t_2} (v(s) - c(s) - sc'(s)) ds = Y(t_1) + x(Y(t_2) - Y(t_1)).$$

Therefore, we can express $x(t_1, t_2)$ as

$$x(t_1, t_2) = \frac{Y(t_1)}{Y(t_1) - Y(t_2)}.$$

Consider the case in which $t_2 > t_1$, *i.e.*, there is a set of types who trade with a probability larger than zero but smaller than one. First, we must have $Y(t_2) - Y(t_1) < 0$, otherwise we may increase x and improve efficiency. This immediately implies $Y(t_1) > 0$. Second, under the optimal mechanism $Y(t_2) < 0$. In fact, if $Y(t_2) \geq 0$, it is possible to implement the mechanism $\mu(t_2)$, which is more efficient than the original one. In particular, this implies that $t_2 > \bar{t}$.

Finally, we must have $t_1 \geq \underline{t}$. Suppose that $t_1 < \underline{t}$. Fix t_2 of the original mechanism and choose $t'_1 \in (t_1, \underline{t}]$. Consider the mechanism under which the types in $[0, t'_1)$ trade with probability 1 while the types in $[t'_1, t_2]$ trade with probability

$$x(t'_1, t_2) = \frac{Y(t'_1)}{Y(t'_1) - Y(t_2)} > \frac{Y(t_1)}{Y(t_1) - Y(t_2)} = x(t_1, t_2),$$

where the inequality follows from $Y(t'_1) > Y(t_1)$ and $Y(t_2) < 0$. Of course, the new mechanism is more efficient than the original one since the types in $[t_1, t_2]$ trade with a larger probability while the types outside this interval trade with the same probability as under the original mechanism.

We summarize our results:

Fact 5 *Let t_1 and t_2 denote the endpoints of the first two steps of the optimal mechanism. Then $t_1 \geq \underline{t}$, and $t_2 \geq \bar{t}$.*

We are now ready to provide a sufficient condition to implement the efficient mechanism in the bargaining game (when the players are sufficiently patient).

Condition 6 For any $t \geq \bar{t}$

$$\int_{\underline{t}}^t (v(s) - c(t)) ds \geq 0.$$

We now explain why the above condition is sufficient. Fix $0 < \tilde{t} \leq 1$, and consider the function $\varphi : [0, \tilde{t}] \rightarrow \mathbb{R}$ given by

$$\varphi(t) := \int_t^{\tilde{t}} (v(s) - c(\tilde{t})) ds.$$

Under our assumptions, if $\varphi(t') \geq 0$ for some t' , then $\varphi(t) > 0$ for every $t \in (t', \tilde{t})$. Recall that the function v is increasing. Let t'' denote the value in $[0, \tilde{t}]$ such that $v(t'') = c(\tilde{t})$ (let $t'' = \tilde{t}$ if $v(\tilde{t}) < c(\tilde{t})$). The function φ is increasing $[0, t'']$. By definition, φ is positive above t'' .

Therefore, fix $t_2 \geq \bar{t}$. Our condition guarantees that for each $t_1 \in [\underline{t}, t_2]$,

$$\int_{t_1}^{t_2} (v(s) - c(t_2)) ds \geq 0,$$

which implies the result, by Proposition 1.

Appendix E: Proof of Proposition 3 (Sketch)

This appendix sketches the proofs of the two harder statements in Proposition 3. We first show that the set of allocations in the buyer veto-incentive compatible program is the same whether or not one imposes *ex post* seller individual rationality. We then show that, as far as payoffs are concerned, the latter requirement can even be strengthened to seller veto-incentive compatibility. In both cases, for simplicity, we restrict attention to finite types. The extension to our set-up with a continuum of types follows by standard limiting arguments.

Lemma 9 *Assume that c and v are step functions with n steps such that $c_1 < c_2 < \dots < c_N$, and (x, p) is an allocation that is implementable in the veto-incentive compatible program. Then there exists a measure μ which induce this allocation such that, for all $t \in T$, we have*

$$\int_{[0, c(t))} \mu(t) [1, dp] = 0.$$

Proof. Since (c, v) are step functions we can consider the model with N types in which the probability of each type is q_i . We write $\{\mu_i\}_{i=1}^N$ for the distribution of offers faced by type i .

Step 1: We divide the type space into 3 subsets:

$$T_1 := \{i \in \{1, \dots, N\} : p_i > v_i\},$$

$$T_2 := \{i \in \{1, \dots, N\} : p_i < v_i\},$$

$$T_3 := \{i \in \{1, \dots, N\} : p_i = v_i\}.$$

Step 2: For $k \leq j$, define

$$L_k^j := \sum_{i=k}^j q_i (x_i (v_i - p_i)).$$

Step 3: Notice that $L_0^N = B(0) \geq 0$, and let J^* be the lowest type i such that $L_0^i \geq 0$. Here we show how to construct an allocation satisfying the properties above for the special case that $J^* = N > 1$. The general proof considers a partition of the type space $\{1, \dots, i_1\}, \{i_1 + 1, \dots, i_2\}, \dots, \{i_{K-1} + 1, \dots, N\}$ and applies this procedure to each set separately.

Step 4: We will present an algorithm which delivers the desired result.

Step 4.1: Let k_1 be the smallest element in T_2 .

There are 2 cases to consider:

Case 1:

$$q_1 x_1 (v_1 - p_1) + q_{k_1} x_{k_1} (v_{k_1} - p_{k_1}) < 0.$$

Case 2:

$$q_1 x_1 (v_1 - p_1) + q_{k_1} x_{k_1} (v_{k_1} - p_{k_1}) \geq 0.$$

Case 1: Notice that since $k_1 > 1$, we have $p_{k_1} \geq p_1$. From type k_1 's individual rationality constraint, we have $p_{k_1} \geq c_{k_1}$. Also, there exists $\lambda \in (0, 1)$ such that

$$\lambda q_1 x_1 (v_1 - p_1) + q_{k_1} x_{k_1} (v_{k_1} - p_{k_1}) = 0. \quad (18)$$

Next, notice that

$$p_1 = \alpha p_{k_1} + (1 - \alpha) v_1, \quad (19)$$

for some $\alpha \in (0, 1]$. Thus, applying (19) into (18) we have

$$0 = \lambda q_1 x_1 (1 - \alpha) (v_1 - v_1) + \lambda q_1 x_1 \alpha (v_1 - p_{k_1}) + q_{k_1} x_{k_1} (v_{k_1} - p_{k_1}). \quad (20)$$

Next, we use (20) to show that $x = x^1 + \hat{x}^1$, where

$$x_i^1 := \begin{cases} \lambda x_1 & \text{if } i = 1, \\ x_{k_1} & \text{if } i = k_1, \\ 0 & \text{otherwise,} \end{cases}$$

and $\hat{x}^1 := x - x^1 \geq 0$. For the allocation (x^1, p) , we construct a measure $\{\mu_i^1\}_{i=1}^N$ such that:

- a. $(\int d\mu^1, \int p d\mu^1) = (x^1, p)$;
- b. If $x_i^1 > 0$ then $\mu_i^1[0, c_i) = 0$.

For that, we define $\mu_i^1 := 0$ if $i \notin \{1, k_1\}$ and

$$\mu_1^1(\tilde{p}) := \begin{cases} \lambda x_1 \alpha & \text{if } \tilde{p} = p_{k_1} \\ \lambda x_1 (1 - \alpha) & \text{if } \tilde{p} = v_1 \\ 0 & \text{otherwise} \end{cases} \quad \mu_{k_1}^1(\tilde{p}) := \begin{cases} x_{k_1} & \text{if } \tilde{p} = p_{k_1}, \\ 0 & \text{otherwise.} \end{cases}$$

Case 2: There exists $(\zeta, \gamma) \in (0, 1] \times (0, 1]$ such that

$$\begin{aligned} p_1 &= \zeta p_{k_1} + (1 - \zeta) v_1, \\ 0 &= q_1 x_1 (1 - \zeta) (v_1 - v_1) + q_1 x_1 \zeta (v_1 - p_{k_1}) + \gamma q_{k_1} x_{k_1} (v_{k_1} - p_{k_1}). \end{aligned}$$

Thus, we define

$$x_i^1 := \begin{cases} x_1 & \text{if } i = 1, \\ \gamma x_{k_1} & \text{if } i = k_1, \\ 0 & \text{otherwise,} \end{cases}$$

and $\hat{x}^1 := x - x^1 \geq 0$. For the allocation (x^1, p) , we construct measures $\{\mu_i^1\}_{i=1}^N$ by setting $\mu_i^1 := 0$ if $i \notin \{1, k_1\}$ and

$$\mu_1^1(\tilde{p}) := \begin{cases} x_1 \zeta & \text{if } \tilde{p} = p_{k_1} \\ x_1 (1 - \zeta) & \text{if } \tilde{p} = v_1 \\ 0 & \text{otherwise} \end{cases} \quad \mu_{k_1}^1(\tilde{p}) = \begin{cases} \gamma x_{k_1} & \text{if } \tilde{p} = p_{k_1}, \\ 0 & \text{otherwise.} \end{cases}$$

Step 4.2: Assume that $x = \sum_{i=1}^M x^i + \hat{x}^M$. There are two possibilities:

Case i. $\{i \in \{1, \dots, N\} : \hat{x}_i^M > 0\} \cap T_1 \neq \emptyset$.

Case ii. $\{i \in \{1, \dots, N\} : \hat{x}_i^M > 0\} \subseteq T_2 \cup T_3$.

Assume that \hat{x}_i^{M-1} is such that $\sum_{i=1}^N q_i (\hat{x}_i^{M-1} (v_i - p_i)) \geq 0$ and $\sum_{i=1}^J q_i (\hat{x}_i^{M-1} (v_i - p_i)) < 0$ if $J < N$. We claim:

Claim 7 If **Step 4.1** is applied to \hat{x}_i^{M-1} , $\hat{x}_i^{M-1} = x_i^M + \hat{x}_i^M$ with $\{i \in \{1, \dots, N\} : \hat{x}_i^M > 0\} \cap T_1 \neq \emptyset$, then $\sum_{i=1}^N q_i (\hat{x}_i^M (v_i - p_i)) \geq 0$ and $\sum_{i=1}^J q_i (\hat{x}_i^M (v_i - p_i)) < 0$ if $J < N$.

Proof: The first conclusion follows since $\sum_{i=1}^N q_i (\hat{x}_i^{M-1} (v_i - p_i)) = \sum_{i=1}^N q_i (\hat{x}_i^M (v_i - p_i))$. For the second, let k_{M-1} be the largest element of $\{i \in \{1, \dots, N\} : \hat{x}_i^{M-1} > 0\} \cap T_2$. There are two possibilities:

- a. $J < k_{M-1} \leq N$. In this case, the result is immediate.
- b. $k_{M-1} \leq J < N$. In this case,

$$\begin{aligned} 0 &> \sum_{i \leq J} q_i (\hat{x}_i^{M-1} (v_i - p_i)) \\ &= \sum_{i \leq J} q_i (\hat{x}_i^{M-1} (v_i - p_i)) + \sum_{i \leq N} q_i ((\hat{x}_i^M - \hat{x}_i^{M-1}) (v_i - p_i)) \\ &= \sum_{i \leq J} q_i (\hat{x}_i^M (v_i - p_i)), \end{aligned}$$

where we used the fact that $k_{M-1} \leq J$ implies

$$0 = \sum_{i \leq N} q_i ((\hat{x}_i^M - \hat{x}_i^{M-1}) (v_i - p_i)) = \sum_{i \leq J} q_i ((\hat{x}_i^M - \hat{x}_i^{M-1}) (v_i - p_i)).$$

■

From Claim 7, we can apply **Step 4.1** into \hat{x}_i^M to obtain x^{M+1} and \hat{x}^{M+1} and $\{\mu_i^{M+1}\}_{i=1}^N$ such that:

a'. $(\int d\mu^{M+1}, \int p d\mu^{M+1}) = (x^{M+1}, p)$;

b'. If $x_i^{M+1} > 0$ then $\mu_i^{M+1}[0, c_i) = 0$.

Notice that this procedure can take (at most) $N - 1$ rounds. In order to complete the Lemma we move to **Case ii**.

Case ii: In this case, define $\{\mu_i^{M+1}\}_{i=1}^N$ by:

$$\mu_i^{M+1}(\tilde{p}) := \begin{cases} \hat{x}_i^M & \text{if } \tilde{p} = p_i \\ 0 & \text{otherwise.} \end{cases}$$

Step 5: Assume the algorithm described in **Step 4.1** and **Step 4.2** was applied to the allocation x such that $x = \sum_{j=1}^K x^j + \hat{x}^k$. Thus it is straightforward to verify that the measure $\{\mu_i\}_{i=1}^N$ defined by $\mu_i(\tilde{p}) := \sum_{j=1}^{K+1} \mu_i^j(\tilde{p})$ is such that $(x, p) = (\int d\mu, \int p d\mu)$ and $\mu_i[0, c_i) = 0$. This completes the proof. ■

We now turn to the other nontrivial claim: seller veto-incentive compatibility does not restrict the set of payoffs that can be achieved in the buyer veto-incentive compatible program. Here as well, attention is restricted to finite types.

Lemma 10 *Assume that the type space is finite and let (π^B, π^S) be a vertex of the payoff frontier achieved in the (buyer) veto-incentive compatible program. There exists a seller veto-incentive compatible measure $\mu = \{\mu_i\}_{i=1}^N$ that achieves this payoff.*

Proof. Assume that there are N types.³³ It can be shown that if (π^B, π^S) is a vertex of the payoff frontier then it is achieved by an allocation (x, p) for which there exists a partition of the type space: $\{\mathcal{P}_j\}_{j=1}^K$ with $\mathcal{P}_1 = \{1, \dots, i_1\}$ and $\mathcal{P}_j = \{i_{j-1} + 1, \dots, i_j\}$, with $i_K \geq 1$ such that:³⁴

- i. If $j < K$, then if $i, i' \in \mathcal{P}_j$ we have $p_i = p_{i'} = \mathbb{E}[v \mid \mathcal{P}_j]$.
- ii. If $j = K$, then we have either a. or b. below:

- a. $(p_i, x_i) = (p_N, x_N)$ for all $i \in \mathcal{P}_K$;

³³For simplicity of exposition we assume that all types trade with positive probability.

³⁴A proof is available upon request.

b. $\mathcal{P}_K = I_1 \cup I_2$ where $I_1 = \{i_{k-1} + 1, \dots, i_l\}$ and $I_2 = \{i_l + 1, \dots, N\}$ with $i_{k-1} \leq i_l < N$ is such that $(p_i, x_i) = (p', x')$ if $i \in I_1$ and $(p_i, x_i) = (p'', x'')$ if $i \in I_2$ with $c_{i_l} \leq \mathbb{E}[v \mid i \in I_1]$ and $p' < p''$.

Here, we prove the more challenging case b.

Step 1: Defining μ_i for $i \notin \mathcal{P}_K$ by:

$$\mu_i(\tilde{p}) := \begin{cases} x_i & \text{if } \tilde{p} = p_i, \\ 0 & \text{otherwise.} \end{cases}$$

Step 2: To define μ_i for $i \in \mathcal{P}_K$, there are two cases to consider:

Case 1: $p' \leq \mathbb{E}[v \mid i \in I_1]$.

In this case we let

$$\mu_i(\tilde{p}) := \begin{cases} x' & \text{if } \tilde{p} = p' \text{ and } i \in I_1 \\ 0 & \text{if } \tilde{p} \neq p' \text{ and } i \in I_1 \end{cases} \quad \mu_i(\tilde{p}) = \begin{cases} x'' & \text{if } \tilde{p} = p'' \text{ and } i \in I_2, \\ 0 & \text{if } \tilde{p} \neq p'' \text{ and } i \in I_2. \end{cases}$$

It is straightforward to check that μ is veto-incentive compatible for the seller.

Case 2: $p' > \mathbb{E}[v \mid i \in I_1]$.

In this case, notice that since the allocation is incentive compatible we must have

$$B_{i_{k-1}+1} = \sum_{i \geq i_{k-1}+1} q_i x_i (v_i - p_i) \geq 0, \quad (21)$$

Furthermore, because $p' \in (\mathbb{E}[v \mid i \in I_1], p'')$, there exists $\alpha \in (0, 1)$ such that

$$p' = \alpha \mathbb{E}[v \mid i \in I_1] + (1 - \alpha) p''. \quad (22)$$

Thus, notice that from (21) and (22),

$$\begin{aligned}
0 &\leq \sum_{i \in I_1} q_i x_i (v_i - p_i) + \sum_{i \in I_2} q_i x_i (v_i - p'') \\
&= \sum_{i \in I_1} \alpha q_i x_i (v_i - \mathbb{E}[v \mid i \in I_1]) \\
&\quad + \sum_{i \in I_1} (1 - \alpha) q_i x_i (v_i - p'') + \sum_{i \in I_2} q_i x_i (v_i - p'').
\end{aligned}$$

Thus, $\sum_{i \in I_1} (1 - \alpha) q_i x_i (v_i - p'') + \sum_{i \in I_2} q_i x_i (v_i - p'') = B_{i_{k-1}+1} \geq 0$.

Therefore, we define μ_i by

$$\mu_i(\tilde{p}) := \begin{cases} \alpha x' & \text{if } \tilde{p} = \mathbb{E}[v \mid i \in I_1] \text{ and } i \in I_1 \\ (1 - \alpha) x' & \text{if } \tilde{p} = p'' \text{ and } i \in I_1 \\ 0 & \text{if } \tilde{p} \notin \{p', p''\} \text{ and } i \in I_1 \end{cases} \quad \mu_i(\tilde{p}) := \begin{cases} x'' & \text{if } \tilde{p} = p'' \text{ and } i \in I_2, \\ 0 & \text{if } \tilde{p} \neq p'' \text{ and } i \in I_2. \end{cases}$$

It is straightforward to verify that the allocation constructed is veto-incentive compatible for the seller. This completes the proof. ■

Appendix F: Proof of Proposition 2

Suppose towards a contradiction that there exists an equilibrium allocation which violates veto-incentive compatibility. Therefore, there exists $\eta > 0$ and $\tilde{t} \in (0, 1)$ such that

$$\int_{\tilde{t}}^1 \sum_{n=0}^{\infty} \delta_n \mathbb{E}_{\sigma^*} [(v(s) - p(s)) \mathbf{1}_{\xi_n} \mid s] ds \leq -\eta, \tag{23}$$

where ξ_n is defined as the event reflecting the object being sold at period n and $\mathbf{1}_{\xi_n}$ is its the indicator function. Consider a typical history in which an offer is made at n , \tilde{h}^n . \tilde{h}^n includes: i) all previous offers (as well as the identity of the proposer) before period n ; ii) The player who makes an offer at n ; iii) the offer made at period n . Given an on-path history \tilde{h}^n , we let $\mu_{\tilde{h}^n}$ be

the associated distribution of types. Since $\lim_{n \rightarrow \infty} \delta_n = 0$ there exists $N \geq 1$ such that for all $n \geq N$ we have:

$$\int_{\tilde{t}}^1 \sum_{n=N}^{\infty} \delta_n \mathbb{E}_{\sigma^*} [(v(s) - p(s)) \mathbf{1}_{\xi_n} | s] d\mu_{\tilde{h}^n} > -\eta. \quad (24)$$

Therefore, let N^* be the largest integer for which there is an on-path history \tilde{h}^{N^*} such that

$$\int_{\tilde{t}}^1 \sum_{n=N^*}^{\infty} \delta_n \mathbb{E}_{\sigma^*} [(v(s) - p(s)) \mathbf{1}_{\xi_n} | s] d\mu_{\tilde{h}^{N^*}} \leq -\eta, \quad (25)$$

and consider a history \tilde{h}^{N^*} satisfying (25). Let p be the offer made by the seller at \tilde{h}^{N^*} and notice that from the definition of N^* we have

$$\int_{\tilde{t}}^1 \delta_n \mathbb{E}_{\sigma^*} [(v(s) - p) \mathbf{1}_{\xi_n} | s] d\mu_{\tilde{h}^{N^*}} < 0. \quad (26)$$

There are two cases:

Case 1: *The seller is selected to make an offer in period T at \tilde{h}^{N^*} .*

From (26) the buyer accepts such an offer with positive probability. Since $v(\cdot)$ is an increasing function (26) implies

$$\int_0^1 \delta_n \mathbb{E}_{\sigma^*} [(v(s) - p) \mathbf{1}_{\xi_n} | s] d\mu_{\tilde{h}^{N^*}} < 0,$$

which shows that the buyer could have profitably deviated by rejecting p , offering 0 in every future period and rejecting every future offer.

Case 2: *The buyer is selected to make an offer in period n at \tilde{h}^{N^*} .*

Let $A \subset [0, \tilde{t}]$ be the set of types who accept this offer with probability 1. There are two possibilities.

Possibility 1: $\mu_{\tilde{h}^{N^*}}(A) = \mu_{\tilde{h}^{N^*}}([0, \tilde{t}])$.

In this case, the expected payoff of the buyer at \tilde{h}^{N^*} is:

$$\begin{aligned}
& \int_0^{\tilde{t}} \sum_{n=N^*}^{\infty} \delta_n \mathbb{E}_{\sigma^*} [(v(s) - p(s)) \mathbf{1}_{\xi_n} \mid s] d\mu_{\tilde{h}^{N^*}} + \int_{\tilde{t}}^1 \sum_{n=N^*}^{\infty} \delta_n \mathbb{E}_{\sigma^*} [(v(s) - p(s)) \mathbf{1}_{\xi_n} \mid s] d\mu_{\tilde{h}^{N^*}} \\
&= \int_0^{\tilde{t}} \delta_n \mathbb{E}_{\sigma^*} [(v(s) - p(s)) \mathbf{1}_{\xi_n} \mid s] d\mu_{\tilde{h}^{N^*}} + \int_{\tilde{t}}^1 \sum_{n=N^*}^{\infty} \delta_n \mathbb{E}_{\sigma^*} [(v(s) - p(s)) \mathbf{1}_{\xi_n} \mid s] d\mu_{\tilde{h}^{N^*}} \\
&\leq \int_{\tilde{t}}^1 \sum_{n=N^*}^{\infty} \delta_n \mathbb{E}_{\sigma^*} [(v(s) - p(s)) \mathbf{1}_{\xi_n} \mid s] d\mu_{\tilde{h}^{N^*}} < 0
\end{aligned} \tag{27}$$

where we have used the fact that $v(\cdot)$ is monotonic to conclude from (25) that the first term in the second line of (27) is nonpositive. Thus the buyer obtains a negative continuation payoff at \tilde{h}^{N^*} , a contradiction.

Possibility 2: $\mu_{\tilde{h}^{N^*}}(A) < \mu_{\tilde{h}^{N^*}}([0, \tilde{t}])$.

In this case, the types $[0, \tilde{t}]/A$ reject the offer. From (25) we know that a positive measure of sellers with types in $[0, \tilde{t}]$ accept this offer. Thus since c is monotonic we conclude that all types in $[0, \tilde{t}]/A$ are indifferent between accepting this offer or not. One can easily show that if all types $[0, \tilde{t}]/A$ were to accept this offer the buyer would be weakly better off. Therefore, it follows from (27) that the buyer obtains a negative continuation payoff at \tilde{h}^{N^*} , a contradiction.

Appendix G: Details for Samuelson's Example 1

Notice that $\mathbb{E}(v) = \frac{1}{2}k + \Delta$. If $k \geq 2$, then $E(v) \geq 1 = c(1)$ for every $\Delta \geq 0$. In words, for any $k \geq 2$ and every $\Delta \geq 0$, the first best is implementable in the veto IC program.

Similarly, if $k \in [0, 2)$ and $\Delta \geq 1 - \frac{1}{2}k$, then the first best is implementable in the veto IC program.

In what follows, let us restrict attention to the set of pairs (k, Δ) with $0 \leq k < 2$ and

$$\max\{0, 1 - k\} < \Delta < 1 - \frac{1}{2}k.$$

Consider the function

$$g(k) = \frac{4}{4-k} - k.$$

Notice that g is strictly decreasing in $[0, 2)$ and

$$\max\{0, 1-k\} < g(k) < 1 - \frac{1}{2}k$$

for every $k \in (0, 2)$ (the three quantities coincide for $k = 0$).

Claim 8 *Fix $k \in (0, 2)$. If $\Delta \in [g(k), 1 - \frac{1}{2}k)$, then condition (9) is satisfied.*

This means that if $\Delta \geq g(k)$, then the most efficient outcome of the full commitment program is implementable in the veto IC program (recall that if $\Delta \geq 1 - \frac{1}{2}k$, then the first best is implementable). When Δ belongs to the nonempty set $[g(k), 1 - \frac{1}{2}k)$, the first best is not implementable in the full commitment program. However, the second best is implementable in the veto IC program.

Proof of the Claim

The function $Y(t)$ is given by

$$Y(t) = \int_0^t (ks + \Delta - t) ds = \frac{1}{2}t(2\Delta - 2t + kt).$$

Let \underline{t} and \bar{t} denote the smallest local maximizer and the smallest strictly positive root of Y , respectively. We have

$$\underline{t} = \frac{\Delta}{2-k}, \quad \bar{t} = \frac{2\Delta}{2-k}.$$

Condition (9) becomes: For every $t \geq \frac{2\Delta}{2-k}$,

$$\begin{aligned} Z(t) &= \int_{\frac{\Delta}{2-k}}^t (ks + \Delta - t) ds \\ &= \frac{1}{2(k-2)^2} (k^3 t^2 - 6k^2 t^2 + 2k^2 t \Delta + 12kt^2 - 10kt\Delta + k\Delta^2 - 8t^2 + 12t\Delta - 4\Delta^2) \geq 0. \end{aligned}$$

For every $k \in [0, 2)$, Z is concave in t . Therefore, it is enough to check that Condition (9) holds at the extremes, $\frac{2\Delta}{2-k}$ and 1. We have

$$\begin{aligned} Z\left(\frac{2\Delta}{2-k}\right) &= \frac{1}{2} k \frac{\Delta^2}{(k-2)^2}, \\ Z(1) &= \frac{1}{2(k-2)^2} (k^3 + 2k^2\Delta - 6k^2 + k\Delta^2 - 10k\Delta + 12k - 4\Delta^2 + 12\Delta - 8). \end{aligned}$$

For every $k \in [0, 2)$, $Z(1)$ is concave in Δ . Consider the expression

$$(k^3 + 2k^2\Delta - 6k^2 + k\Delta^2 - 10k\Delta + 12k - 4\Delta^2 + 12\Delta - 8).$$

The roots are

$$g(k) = \frac{4}{4-k} - k, \quad 2 - k.$$

Therefore, if $\Delta \in [g(k), 1 - \frac{1}{2}k)$, then $Z(1) \geq 0$ and Condition (9) is satisfied.

Appendix H: Markov Equilibria

In this appendix, we show that, at least in the case of finitely (but arbitrarily) many types, restricting attention to Markov perfect equilibria does not restrict the set of limit equilibrium payoffs that we characterize in the bargaining game. A *Markovian* strategy is a strategy that only depends on the (public) belief about the seller's type. An equilibrium is Markov perfect if it involves Markovian strategies.

We assume that there are N types: $T := \{t_1, \dots, t_N\}$ and that c and v are strictly monotone

in t . Let q_i be the probability of type t_i .

We claim that any regular allocation (x, p) can be approximately implemented by Markov strategies when the parties are patient. In a regular allocation, there is a monotone partition of the type space $\{\mathcal{T}_1, \dots, \mathcal{T}_M\}$. We focus on the case in which all types trade with positive probability and in which $M > 3$ (the other cases are analogous). For every $k \in \{1, \dots, M\}$, types $t \in \mathcal{T}_k$ trade with probability x_k at a price p_k . Notice that $1 = x_1 > \dots > x_M$ and $v(t_1) \leq p_1 < \dots < p_M$. For every $k \in \{1, \dots, M\}$, let $i(k) := \min\{i : t_i \in \mathcal{T}_k\}$ and $j(k) := \max\{i : t_i \in \mathcal{T}_k\}$. Define $\underline{t}^k = t_{i(k)}$ and $\bar{t}^k := t_{j(k)}$. We have: $B(\underline{t}^1) \geq 0$, $B(\underline{t}^k) = 0$ for every $k < M$ and $B(\underline{t}^M) > 0$. Furthermore, all local incentive constraints bind.

For each $k \in \{1, \dots, M\}$ define

$$v(\mathcal{T}_k) := \frac{\sum_{t \in \mathcal{T}_k} q_i v(t_i)}{\sum_{t \in \mathcal{T}_k} q_i}.$$

Take $\varepsilon > 0$. For (close enough to one) δ we specify a Markovian equilibrium that implements the allocation (x^δ, p^δ) . The family of allocations (x^δ, p^δ) satisfy $\lim_{\delta \uparrow 1} \|(x^\delta, p^\delta) - (x, p)\| < \varepsilon$.

Step 1: *Defining an implementable allocation (x', p') close to (x, p) which satisfies additional properties.*

Using the fact that c is strictly monotone and all local incentive constraints bind in (x, p) , it is straightforward to construct an allocation (x', p') such that:

- a) Every type $t \in \mathcal{T}_k$ trades with the same probability and with the same price. The allocation is monotonic satisfies $x'_1 = 1$ and $p_1 \geq v(t_1)$.
- b) $B(t^1) \geq 0$, $B(t^k) = 0$ for every $k < M$ and $B(t^M) > 0$.
- c) For every $k \in \{1, \dots, M - 3\}$, the type \bar{t}^k strictly prefer (x'_k, p'_k) to (x'_{k+1}, p'_{k+1}) .
- d) For every $k \in \{M - 2, M - 1\}$, the type \bar{t}^k is indifferent between (x'_k, p'_k) to (x'_{k+1}, p'_{k+1}) .
- e) Type t_M obtains a strictly positive payoff: $x_M(p_M - c(t_M)) > 0$.
- f) It holds that $\|(x', p') - (x, p)\| < \frac{\varepsilon}{2}$.

With some abuse of notation we assume that the original allocation (x, p) satisfies a)–f).

Step 2: *Constructing a Markovian equilibrium.*

The construction is divided into steps (1)–(7).

(1) All types $t \in \mathcal{T}_1$ make an offer p_1 at $n = 0$. The buyer accepts this offer with probability 1.

(2) Consider types $t \in \mathcal{T}_k$ for $1 < k < M - 2$. All such types offer p_k in every period $n \geq 0$. The buyer randomizes and accepts this offer with probability ψ_k^δ in each period. We set ψ_k^δ such that:

$$x_k = \psi_k^\delta + \delta(1 - \psi_k^\delta)\psi_k^\delta + \dots = \left(\frac{\psi_k^\delta}{1 - \delta(1 - \psi_k^\delta)} \right). \quad (28)$$

(3) Consider types $t \in \mathcal{T}_{M-2}$. For each small $\eta > 0$ let

$$p^{M-2}(\eta) := \frac{\sum_{t_i \in \mathcal{T}_{M-2}/\{\bar{t}^{M-2}\}} q_i v(t_i) + q_{j(M-2)} v(\bar{t}^{M-2})(1 - \eta)}{\sum_{t_i \in \mathcal{T}_{M-2}/\{\bar{t}^{M-2}\}} q_i + q_{j(M-2)}(1 - \eta)}. \quad (29)$$

That is, assume that a measure $\eta q_{j(M-2)}$ of the type \bar{t}^{M-2} “leaves” the partition \mathcal{T}_{M-2} . Thus, $p^{M-2}(\eta)$ is the expected value to the buyer from this new set. Notice that since $M > 3$, we have $B(\underline{t}^{M-2}) = B(\underline{t}^{M-1}) = 0$ and hence $p_{M-2} = v(\mathcal{T}_{M-2})$. Consequently, we have $\lim_{\eta \rightarrow 0} p^{M-2}(\eta) = p^{M-2}$.

All types $t_i \in \mathcal{T}_{M-2}/\{\bar{t}^{M-2}\}$ offer $p^{M-2}(\eta)$ in every period $n \geq 0$. The type \bar{t}^{M-2} randomizes. With probability $(1 - \eta)$, he “joins” this partition and offers $p^{M-2}(\eta)$ in every period $n \geq 0$. With complementary probability his behavior is determined in point (4) below. The probability that the offer $p^{M-2}(\eta)$ is accepted in each period, ψ_{M-2}^δ , is set to yield the payoff $x_{M-2}(p_{M-2} - c(\bar{t}^{M-2}))$ to type \bar{t}^{M-2} :

$$x_{M-2}(p_{M-2} - c(\bar{t}^{M-2})) = \left(\frac{\psi_{M-2}^\delta}{1 - \delta(1 - \psi_{M-2}^\delta)} \right) (p^{M-2}(\eta) - c(\bar{t}^{M-2})). \quad (30)$$

For future reference, let $\bar{\psi}_{M-2}^\delta$ solve:

$$x_{M-2}(p_{M-2} - c(\bar{t}^{M-2})) = \left(\frac{\bar{\psi}_{M-2}^\delta}{1 - \delta(1 - \bar{\psi}_{M-2}^\delta)} \right) (v(\bar{t}^{M-2}) - c(\bar{t}^{M-2})), \quad (31)$$

and notice that $\bar{\psi}_{M-2}^\delta < \psi_{M-2}^\delta$ if and only if $\mathcal{T}_{M-2} \setminus \{\bar{t}^{M-2}\} \neq \emptyset$.

(4) Next, we specify the behavior of the remaining types. Remember that $B(\underline{t}^{M-1}) = 0$ and $B(\underline{t}^M) > 0$ and hence $p_{M-1} > v(\mathcal{T}_{M-1})$. Therefore, there is a unique $\beta \in (0, 1)$ such that:

$$x_{M-1}p_{M-1} = \beta x_{M-1}v(\mathcal{T}_{M-1}) + (1 - \beta)x_{M-1}v(\mathcal{T}_{M-1} \cup \mathcal{T}_M). \quad (32)$$

At period $n = 0$, all types $t \in \mathcal{T}_{M-2} \cup \mathcal{T}_{M-1}$ together with a measure $(\frac{\eta}{2})$ of type \bar{t}^{M-2} offer

$$p_0^{M-1, M-2} := \frac{\sum_{t_i \in \mathcal{T}_{M-2} \cup \mathcal{T}_{M-1}} q_i v(t_i) + q_{j(M-2)} v(\bar{t}^{M-2}) \left(\frac{\eta}{2}\right)}{\sum_{t_i \in \mathcal{T}_{M-2} \cup \mathcal{T}_{M-1}} q_i + q_{j(M-2)} \left(\frac{\eta}{2}\right)}. \quad (33)$$

The buyer accepts this offer with probability ψ_0^δ . This probability is set such that the type \bar{t}^{M-2} is indifferent between:

a) Offering $v(\bar{t}^{M-2})$ in every future period. In this case, the buyer randomizes and accepts this offer with probability $\bar{\psi}_{M-2}^\delta$ (see (31)) the type \bar{t}^{M-2} obtains a payoff $x_{M-2}(p_{M-2} - c(\bar{t}^{M-2}))$.

b) Offering $p_0^{M-1, M-2}$ for one period. If the buyer rejects it (which happens with probability $(1 - \psi_0^\delta)$) the seller reverts to strategy a) in the next period.

A measure $(\frac{\eta}{2})$ of type \bar{t}^{M-2} chooses b).

Inductively, we define

$$p_n^{M-1, M-2} := \frac{\sum_{t_i \in \mathcal{T}_{M-2} \cup \mathcal{T}_{M-1}} q_i v(t_i) + q_{j(M-2)} v(\bar{t}^{M-2}) \left(\frac{\eta}{2^{n+1}}\right)}{\sum_{t_i \in \mathcal{T}_{M-2} \cup \mathcal{T}_{M-1}} q_i + q_{j(M-2)} \left(\frac{\eta}{2^{n+1}}\right)}, \quad (34)$$

and define ψ_n^δ analogously for all $n \leq n^*$ (n^* is defined below). Notice that the total discounted

probability that the buyer purchases the good in periods $n = 0, \dots, n^*$ is:

$$X_{n^*}^\delta := \psi_0^\delta + \delta(1 - \psi_0^\delta)\psi_1^\delta + \dots + \delta^{n^*} \left[\prod_{n=0}^{n^*-1} (1 - \psi_n^\delta) \right] \psi_{n^*}^\delta. \quad (35)$$

Next, define n^* as the minimum integer n such that $X_n^\delta \geq (1 - \beta)x_{M-1}$ (see (32)). It is straightforward to show that the difference $|X_{n^*}^\delta - (1 - \beta)x_{M-1}| \rightarrow 0$ as $\delta \uparrow 1$ and $\eta \rightarrow 0$. Below we define the continuation behavior after n^* .

The type \bar{t}^{M-2} offers $v(\bar{t}^{M-2})$ in every future period (and this offer is accepted with probability $\bar{\psi}_{M-2}^\delta$).

All types $t \in \mathcal{T}_{M-1}$ offer $v(\mathcal{T}_{M-1})$. This offer is accepted with constant probability ψ_{M-1}^δ in every future period. $\bar{\psi}_{M-1}^\delta$ is set such that to make type \bar{t}^{M-2} indifferent:

$$\left(\frac{\bar{\psi}_{M-2}^\delta}{1 - \delta(1 - \bar{\psi}_{M-2}^\delta)} \right) (v(\bar{t}^{M-2}) - c(\bar{t}^{M-2})) = \left(\frac{\psi_{M-1}^\delta}{1 - \delta(1 - \psi_{M-1}^\delta)} \right) (v(\mathcal{T}_{M-1}) - c(\bar{t}^{M-2})). \quad (36)$$

All types $t \in \mathcal{T}_M$ offer $v(\mathcal{T}_M)$. This offer is accepted with constant probability ψ_M^δ in every future period. ψ_M^δ is set to make type \bar{t}^{M-1} indifferent:

$$\left(\frac{\psi_{M-1}^\delta}{1 - \delta(1 - \psi_{M-1}^\delta)} \right) (v(\mathcal{T}_{M-1}) - c(\bar{t}^{M-1})) = \left(\frac{\psi_M^\delta}{1 - \delta(1 - \psi_M^\delta)} \right) (v(\mathcal{T}_M) - c(\bar{t}^{M-2})). \quad (37)$$

Next, we explain in (5) why the induced allocation (x^δ, p^δ) is close to (x, p) when η is small and δ large. Then we verify in (6) that the induced allocation is indeed an equilibrium when η is small and δ large. In (7) we show that the equilibrium is Markovian.

(5) It is clear that for all $k < M - 1$ all $t \in \mathcal{T}_k$ trade with probability $x^\delta(t)$ close to $x(t)$ and at a price $p^\delta(t)$ close to $p(t)$ (when η is small and δ large). Next, we consider types $t \in \mathcal{T}_{M-1}$. From (36) the type \bar{t}^{M-2} is indifferent between the allocation $(x^\delta(t), p^\delta(t))$ and always imitating

types $t \in \mathcal{T}_{M-1}$. Therefore, using (30) and (36) we obtain:

$$\begin{aligned}
& x_{M-2}(p_{M-2} - c(\bar{t}^{M-2})) \tag{38} \\
&= \psi_0^\delta \left(p_0^{M-1, M-2} - c(\bar{t}^{M-2}) \right) + \dots + \delta^{n^*} \left[\prod_{n=0}^{n^*-1} (1 - \psi_n^\delta) \right] \psi_{n^*}^\delta \left(p_{n^*}^{M-1, M-2} - c(\bar{t}^{M-2}) \right) \\
&+ \delta^{n^*+1} \left(\prod_{n=0}^{n^*} (1 - \psi_n^\delta) \right) \left(\frac{\psi_{M-1}^\delta}{1 - \delta(1 - \psi_{M-1}^\delta)} \right) (v(\mathcal{T}_{M-1}) - c(\bar{t}^{M-2})).
\end{aligned}$$

Next, notice that as $\eta \rightarrow 0$ we have $p_{n^*}^{M-1, M-2} \rightarrow v(\mathcal{T}_{M-1} \cup \mathcal{T}_M)$ and as $\delta \uparrow 1$ we have $|X_{n^*}^\delta - (1 - \beta)x_{M-1}| \rightarrow 0$. Therefore, for any $\kappa > 0$ we can find $\eta_1 > 0$ and $\delta_1 \in (0, 1)$ such that whenever $\eta < \eta_1$ and $\delta > \delta_1$ we have:

$$\left| \begin{aligned}
& \psi_0^\delta \left(p_0^{M-1, M-2} - c(\bar{t}^{M-2}) \right) + \dots + \delta^{n^*} \left[\prod_{n=0}^{n^*-1} (1 - \psi_n^\delta) \right] \psi_{n^*}^\delta \left(p_{n^*}^{M-1, M-2} - c(\bar{t}^{M-2}) \right) \\
& - (1 - \beta)x_{M-1}v(\mathcal{T}_{M-1} \cup \mathcal{T}_M)
\end{aligned} \right| < \kappa.$$

Thus, for such parameters we have

$$\begin{aligned}
& x_{M-2}(p_{M-2} - c(\bar{t}^{M-2})) \tag{39} \\
&= (1 - \beta)x_{M-1}(v(\mathcal{T}_{M-1} \cup \mathcal{T}_M) - c(\bar{t}^{M-2})) \\
&+ \delta^{n^*+1} \left(\prod_{n=0}^{n^*} (1 - \psi_n^\delta) \right) \left(\frac{\psi_{M-1}^\delta}{1 - \delta(1 - \psi_{M-1}^\delta)} \right) (v(\mathcal{T}_{M-1}) - c(\bar{t}^{M-2})) + z^\delta,
\end{aligned}$$

where $z^\delta \leq |\kappa|$. Next, using (32) and the fact that type \bar{t}^{M-2} is indifferent between the allocations (x_{M-2}, p_{M-2}) and (x_{M-1}, p_{M-1}) , we have

$$\begin{aligned}
& x_{M-2}(p_{M-2} - c(\bar{t}^{M-2})) \tag{40} \\
&= \beta x_{M-1}(v(\mathcal{T}_{M-1}) - c(\bar{t}^{M-2})) + (1 - \beta)x_{M-1}(v(\mathcal{T}_{M-1} \cup \mathcal{T}_M) - c(\bar{t}^{M-2})).
\end{aligned}$$

From (39) and (40) we immediately have:

$$\begin{aligned} & \beta x_{M-1}(v(\mathcal{T}_{M-1}) - c(\bar{t}^{M-2})) \\ = & \delta^{n^*+1} \left(\prod_{n=0}^{n^*} (1 - \psi_n^\delta) \right) \left(\frac{\psi_{M-1}^\delta}{1 - \delta(1 - \psi_{M-1}^\delta)} \right) (v(\mathcal{T}_{M-1}) - c(\bar{t}^{M-2})) + z^\delta, \end{aligned}$$

which implies that $\delta^{n^*+1} \left(\prod_{n=0}^{n^*} (1 - \psi_n^\delta) \right) \left(\frac{\psi_{M-1}^\delta}{1 - \delta(1 - \psi_{M-1}^\delta)} \right) \rightarrow \beta x_{M-1}$. Using a similar argument we conclude that for all $t \in \mathcal{T}_M$ the allocation $(x^\delta(t), p^\delta(t))$ can be made as close as we want to $(x(t), p(t))$ by taking η is small and δ close to 1.

(6) We show that the induced allocation is indeed an equilibrium.

We start defining the off-path behavior. First, consider a deviation by the buyer. The only off-path action is to reject the offer p_1 at $n = 0$ (as the buyer should randomize over all other offers). If the buyer rejects p_1 at $n = 0$, the equilibrium specifies that the buyer does not update his belief and accepts the same offer with probability 1 in the next period. Following this deviation, the equilibrium prescribes that seller makes the same offer in the subsequent period. If the seller deviates and do not offer p_1 the continuation equilibrium is the same as the one triggered by an off-path offer made by the seller (see below).

Now, consider an off-path deviation by the seller. First, assume that the seller makes an off-path offer. In this case, we impose that the buyer puts probability 1 on the seller being type t_1 and he never revises his belief again. The buyer accepts any future offer p if and only if $p \leq v(t_1)$. Type t_i offers $v(t_1)$ if $(v(t_1) - c(t_i)) \geq 0$ and $v(t_M) + 1$ otherwise. Therefore, he guarantees a payoff $[v(t_1) - c(t_i)]^+$. We postpone the description of the seller's continuation strategy after a deviation to an offer which is made on the equilibrium path to the end of (6).

Now, we show that the buyer does not have a profitable deviation. Notice that since $B(\underline{t}^1) \geq 0$ and $B(\underline{t}^2) = 0$ we have $v(\mathcal{T}_1) \geq p_1$ and hence the buyer would never profit by rejecting the offer p_1 . Next, notice that the buyer obtains zero payoffs from all other (on-path) offers and hence he

cannot profitably deviate by accepting or rejecting any such offer with probability 1. Finally, consider the buyer off-path behavior induced by a seller deviation. In this case, the buyer puts probability 1 on the seller having type t_1 . Since no offer lower than $v(t_1)$ will ever be made, it is evident that the strategy of accepting an offer p if and only if $p \leq v(t_1)$ is optimal.

Let us now show that the seller has no profitable deviation.

First, consider a seller with a type $t < \bar{t}^{M-2}$ and assume that $t \in \mathcal{T}_k$. Let us first contemplate the deviation to some offer $p_j \in \{p_1, \dots, p_{M-3}\} \setminus \{p_k\}$ in the first period. Notice that since the buyer's acceptance rate is constant we may (w.l.o.g.) assume that the seller offers p_j in every subsequent period. Since the allocation (x, p) is monotonic and incentive compatible, (28) implies that there is no profitable deviation.

Next, let us consider a deviation to the offer $p_{M-2}(\eta)$ at $n = 0$ (thus assume implicitly that $k < M - 2$). Notice that we have assumed in (c) in Step 1 that type \bar{t}^{M-3} strictly prefer (x_{M-3}, p_{M-3}) to (x_{M-2}, p_{M-2}) . Notice that the allocation $(x_{M-2}^\delta, p_{M-2}(\eta))$ approaches (x_{M-2}, p_{M-2}) as $\eta \downarrow 0$. Therefore, offering $p_{M-2}(\eta)$ at every $n \geq 0$ is strictly dominated by following the equilibrium strategy.

Finally, let us contemplate the deviation to some offer $p \in \{v(\bar{t}^{M-2}), p_0^{M-1, M-2}\}$ in the first period. Assume that type t seller deviates by pooling with types $t \in \mathcal{T}_{M-1} \cup \mathcal{T}_M$ until period $n \leq n^*$.

First, assume that $n = n^*$. At time $n^* + 1$ one of the following 4 options is a best-response for type t : i) Offer $v(t_1)$ in every $n \geq n^* + 1$ with the buyer accepting this offer with constant probability 1 in each future period; ii) Offer $v(\bar{t}^{M-2})$ in every $n \geq n^* + 1$ with the buyer accepting this offer with constant probability $\bar{\psi}_{M-2}^\delta$ in each future period; iii) Offer $v(\mathcal{T}_{M-1})$ in every $n \geq n^* + 1$ with the buyer accepting this offer with constant probability ψ_{M-1}^δ in each future period; iv) Offer $v(\mathcal{T}_M)$ in every $n \geq n^* + 1$ with the buyer accepting this offer with constant probability ψ_M^δ in each future period. By construction type \bar{t}^{M-1} is indifferent between iii) and iv), hence by single-crossing type \bar{t}^{M-2} prefers iii) to iv). By construction type \bar{t}^{M-2} is indifferent

between iii) and ii). Furthermore, since $x_{M-2}(p_{M-2} - c(\bar{t}^{M-2})) \geq (v(t_1) - c(\bar{t}^{M-2}))$ (because we have a regular allocation) we conclude that option ii) is a best-response to type \bar{t}^{M-2} . Thus, from single-crossing any best-response for type t is either i) or ii).

Next, let us analyze the incentives of type t at period n^* . Consider the fictional environment in which the possibilities of type t are enriched at period n^* : He has options i), ii) (above) and v): Offer $p_{n^*}^{M-1, M-2}$ in every period $n \geq n^*$ with the buyer accepting this offer with constant probability $\psi_{n^*}^\delta$ in each future period. Type \bar{t}^{M-2} is indifferent between ii) and v) and hence type t would never choose v) at n^* . Thus we conclude that type t would never pool with types $t \in \mathcal{T}_{M-1} \cup \mathcal{T}_M$ until period n^* . The (essentially) same argument implies that type t would never pool with types $t \in \mathcal{T}_{M-1} \cup \mathcal{T}_M$ until period $n = n^* - 1$.

By induction, we conclude that type t never pool with types $\mathcal{T}_{M-1} \cup \mathcal{T}_M$ and hence he has a best-response in which he offers $p \in \{p_1, \dots, p_{M-2}(\eta), v(\bar{t}^{M-2})\}$ in every $n \geq 0$. However, type \bar{t}^{M-2} is indifferent between offering $\{p_{M-2}(\eta), v(\bar{t}^{M-2})\}$ in every $n \geq 0$. Thus, from single-crossing we conclude that type t has a best-response in the set $\{p_1, \dots, p_{M-2}(\eta)\}$. Therefore, from the analysis in the previous two paragraphs we conclude that type t does not have a profitable deviation.

One can use an analogous argument to show that no type $t > \bar{t}^{M-2}$ has a profitable deviation.

Finally, we specify the seller's strategy after a deviation to an offer which is made on the equilibrium path. We consider a type $t < \bar{t}^{M-2}$. A similar construction holds for every type $t \geq \bar{t}^{M-2}$ (omitted for brevity). First, assume that type $t \in \mathcal{T}_k$ has deviated in every period $n \leq \tilde{n}$ and offered $p \in \{p_1, \dots, p_{M-2}(\eta), v(\bar{t}^{M-2})\}$ and let $\psi^\delta(p)$ the (constant) probability that the buyer accepts this offer in each future period. The best-response of the seller depends on the argmax of

$$A := \left\{ \left(\frac{\psi^\delta(p)}{1 - \delta(1 - \psi^\delta(p))} \right) (p - c(t)), (v(t_1) - c(t)), 0 \right\}.$$

If $0 \in \arg \max A$ then the seller offers $v(t_M) + 1$ in every future period. Otherwise, if

$\left(\frac{\psi^\delta(p)}{1-\delta(1-\psi^\delta(p))}\right) (p - c(t)) \in \arg \max A$ the seller offers p in each future period.

Finally, if $(v(t_1) - c(t)) = \arg \max A$, the seller offers $v(t_1)$ in each future period.

Next, assume that type t has offered $p_n^{M-1, M-2}$ in every period $n \leq \tilde{n}$ ($\tilde{n} \leq n^*$). We have to compare $\left(\frac{\bar{\psi}_{M-2}^\delta}{1-\delta(1-\bar{\psi}_{M-2}^\delta)}\right) (v(\bar{t}_{M-2}) - c(t))$ and $(v(t_1) - c(t))$. If $\left(\frac{\bar{\psi}_{M-2}^\delta}{1-\delta(1-\bar{\psi}_{M-2}^\delta)}\right) (v(\bar{t}_{M-2}) - c(t)) \geq (v(t_1) - c(t))$ (resp. $\left(\frac{\bar{\psi}_{M-2}^\delta}{1-\delta(1-\bar{\psi}_{M-2}^\delta)}\right) (v(\bar{t}_{M-2}) - c(t)) < (v(t_1) - c(t))$) the seller offers $v(\bar{t}_{M-2})$ (resp. $v(t_1)$) in every future period.

Now, assume that type t has offered $p_n^{M-1, M-2}$ in every period $n \leq n^*$. and offered $p \in \{v(\bar{t}^{M-2}), v(\mathcal{T}_{M-1}), v(\mathcal{T}_M)\}$ in every period $n \in \{n^* + 1, \dots, n^* + k\}$. Let $\psi^\delta(p)$ be the (constant) probability that the buyer accepts the offer p in each period. As above, hen the seller's offer in every future period is determined by the maximizer of A .

The case in which the seller has offered $p_n^{M-1, M-2}$ in every period $n \leq \tilde{n}$ ($\tilde{n} \leq n^*$) and has offered $v(\bar{t}^{M-2})$ in every period $n \in \{\tilde{n} + 1, \dots, \tilde{n} + k\}$ is clearly analogous to the cases above (omitted for brevity).

(7) Now we establish that the strategies are Markovian.

Let

$$\mathbf{P} := \{p_1, \dots, p_{M-3}, p_{M-2}(\eta), v(\bar{t}^{M-2}), p_0^{M-1, M-2}, \dots, p_{n^*}^{M-1, M-2}, v(\mathcal{T}_{M-1}), v(\mathcal{T}_M)\}$$

be the set of on-path offers (assume that $p_{M-2}(\eta) \neq v(\bar{t}^{M-2})$, otherwise eliminate $v(\bar{t}^{M-2})$ from \mathbf{P}).

Notice that in the equilibrium that we constructed, the behavioral strategy of type t at a history h depends on which partition the history h belongs to.

i) Partition 1: $h = \emptyset$, the initial history;

ii) Partition p ($p \in \mathbf{P}$, thus there are $|\mathbf{P}|$ of such partitions): $h \neq \emptyset$ and “no deviation” has been detected by the buyer. In this case, the behavioral strategy of the type t seller depends only on the offer p that was made in the last period.

iii) Partition D : The buyer detected a deviation in h . (Remember that in this case the offer made by type t is determined by $\arg \max \{(v(t_1) - c(t)), 0\}$.)

Notice that the history i) is associated to the initial belief $\mathbf{q}_0 \in \Delta(T)$. Notice also that if the buyer has not detected any deviation then each offer $p \in \mathbf{P}$ made in the last period leads to a different posterior which we call $\mathbf{q}(p)$. Finally, notice that if an offer belongs to the partition D then the buyer puts a probability 1 on the seller being type t_1 . We write $\mathbf{q}(\{t_1\})$ for this posterior.³⁵ Therefore, the seller's strategy depends only on the prior \mathbf{q} ($\mathbf{q} \in \{\mathbf{q}(\{t_1\}), \mathbf{q}_0\} \cup \{\mathbf{q}(p) : p \in \mathbf{P}\}$).

Finally, since the buyer's behavioral strategy precludes that he accepts any on-path $p \in \mathbf{P}$ with probability $\psi^\delta(p)$ and accepts any off-path offer if and only if it is no greater than $v(t_1)$ we conclude that the buyer plays a Markovian strategy.

References

Billingsley, P. (1968). *Convergence of Probability Measures*, John Wiley & Sons.

³⁵We remark that if $\mathcal{T}_1 = \{t_1\}$ then the partitions D and p_1 (notice that in this case $p_1 = v(t_1)$) are the same. This causes no difficulty.